



# INDUSTRIAL VIBRATORS

ELECTRIC VIBRATORS FOR INDUSTRIAL APPLICATIONS



THE WORLDWIDE LEADER IN VIBRATION TECHNOLOGY





<b>Company profile</b>	4
<b>Technical features</b>	6

### **MVE Standard Range**

2 poles	12
4 poles	14
6 poles	16
8 poles	18
2 poles single-phase	20
MVE-MICRO	22
MVE-DC Direct Current	24

### **MVE-Exe Increased Safety**

2 poles	26
4 poles	28
6 poles	30
8 poles	32

### **MVE-Exd Explosion-Proof**

2 and 4 poles	34
6 and 8 poles	36

### **MVE-Milling Grain Processing**

6, 8, 10, 12 poles	38
--------------------	----

### **MVE-SV Screen Vibrator**

4 poles	40
---------	----

### **MVE-SS Stainless Steel**

2, 4, 6, 8 poles	42
------------------	----

### **MVE-FD Flanged Drive**

6, 8 poles	44
------------	----

<b>Installation</b>	48
<b>Technical drawings</b>	extra page



**Worldwide leader in vibration technology**

## OUR 3 DIVISIONS

PROVIDE CUSTOMERS WITH OPTIMAL SOLUTIONS FOR ALL REQUIREMENTS

### INDUSTRIAL VIBRATORS



Electric vibrators and oscillating mounts for vibrating equipment.

### FLOW AIDS



Electric and pneumatic vibrators to solve any flowability problem.

### CONCRETE CONSOLIDATION



High frequency vibrators, converters and accessories for concrete compaction.



Founded in 1960 in Milan, OLI has undergone remarkable evolution, solidifying its position as **the world's top-selling manufacturer of Industrial Vibrators**. The company has expanded its global presence with **24 Trading Subsidiaries**, over **70 local warehouses**, and **4 manufacturing plants**.

Initially focused on immersion vibrators for concrete consolidation, OLI has emerged as a global leader in vibration technology. Offering a diverse range of **electric** and **pneumatic internal and external vibrators**, OLI seamlessly integrates performance and reliability to adapt to dynamic market demands.

OLI has refined its business strategy to prioritize **rapid stock delivery** and

unparalleled **technical assistance**, ensuring customers worldwide have prompt access to **top-tier products and support**. Exceptional customer service is a cornerstone of OLI's operations, characterized by efficient order processing and universal access to high-quality products and services.

The company boasts a **team of specialized engineers** supported by globally certified management, ready to offer the expertise needed to address customer needs efficiently and safely.

OLI is not only committed to providing cutting-edge equipment but is also at the forefront of **developing innovative products**, aiming to maintain its leadership in the vibration technology industry and continuously set new standards.



# TECHNICAL FEATURES

## QUALITY



- World class materials
- Class F insulation
- Durable sealing
- Premium bearings
- Strong body design - FEM designed
- Vacuum insulation
- FMEA analysis
- 3D quality check

## EFFICIENCY

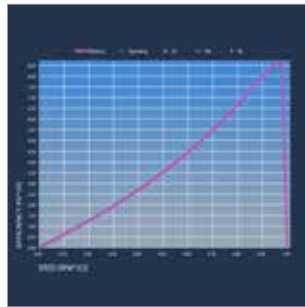

- Optimised power/weight ratio
- S1 continuous duty service
- Optimized electric design

## RELIABILITY



- PTC thermistor 130 °C
- Specific grease retaining device
- Tropicalised standard
- IP66 protection
- Class F insulation

## FLEXIBILITY

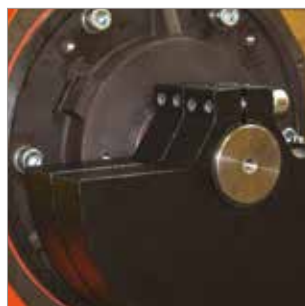

- Easy mass adjustment
- Various voltages and frequencies available
- Easy access to the terminal box
- Multiple eye-bolts



## Standard specifications

Specification	PRODUCT RANGE					
	Standard	Increased Safety	Explosion-Proof	Milling Grain Processing	Screen Vibrator	Stainless Steel
Power supply	Three-phase from 24V to 690V. 50Hz or 60Hz. Single phase 110V 60Hz and 220V 50Hz. Three-phase motors are designed for inverter application.	Three-phase from 230V to 500V. 50Hz or 60Hz. All motors are designed for inverter application from 20Hz to rated frequency.	Three-phase from 220V to 575V. 50Hz or 60Hz. All motors are designed for inverter application from 20Hz to rated frequency.		Three-phase from 220V to 575V. 50Hz or 60Hz. All motors are designed for inverter application from 20Hz to rated frequency.	
Time rating	Continuous duty (S1).					
Protection structure	Mechanical protection IP66 according to IEC 60529.					
Bearings	Ball bearings from size MICRO to 50. Roller bearings from size 60 to 110.	Ball bearings from size 10 to 50. Roller bearings from size 60 to 90.	Roller bearings.			Ball bearings from size 10 to 50* Roller bearing for size 60.
Coating colour	Polyester powder coating. Standard colour RAL 2009. Special corrosion resistant painting available on request on Standard range only.					AISI 316 frame not painted.
Footprint	Compatibility with the main competitor's footprint on request.					/
Installation and operating environment	For indoor and outdoor use.					
	Ambient temperature: from -20 °C to +40 °C. Up to +55 °C available on request.	Ambient temperature: from -20 °C to +40 °C.	Ambient temperature: from -20 °C to +60 °C.	Ambient temperature: from -20 °C to +40 °C.	Ambient temperature: from -20 °C to +40 °C.	Ambient temperature: from -20 °C to +40 °C.
Standards supported	Conformity with European Directive. Low voltage 2014/35/UE. Machine directive 2006/42/EC. ATEX 2014/34/UE.					
Mass covers	Aluminium, for vibrators from size 10 to size 50 and size 100, 105, 110. Mild steel, for size 60 to size 91. Stainless steel AISI 304, for direct current motovibrators.	Aluminium, for vibrators from size 10 to size 50. Mild Steel, for size 60 to size 91.	AISI 304 Stainless Steel.	Mild Steel.	Aluminium.	AISI 304 Stainless Steel.
Windings	2, 4, 6 and 8 poles three-phase asynchronous motor from size 10 to 110. 2 poles single phase from size 10 to 30.	2, 4, 6 and 8 poles three-phase asynchronous motor.		6, 8, 10 and 12 poles three-phase asynchronous motor.	4 poles.	2, 4, 6 and 8 poles three-phase asynchronous motor.
	Class F insulating materials (155 °C). Vacuum impregnated windings. PTC thermistor 130 °C standard from size 60.		Thermal switch 130 °C standard from size 60.	Class F insulating materials (155 °C). Vacuum impregnated windings. PTC thermistor 130 °C standard from size 60.	Thermal switch 130 °C.	Class F insulating materials (155 °C). Vacuum impregnated windings.
Flanges	Grey cast iron up to size 80. Ductile cast iron from size 100.				Ductile cast iron.	Grey cast iron.
Frame	Aluminium up to size 50. Ductile cast iron from size 60.				Aluminium.	AISI 316.
Shaft	Steel alloy highly resistant.					
Eccentric masses	Completely adjustable.					

\* Except for MVE 710/15N-50A0 and MVE 510/1N-50A0



# The OLI Vibrator Range

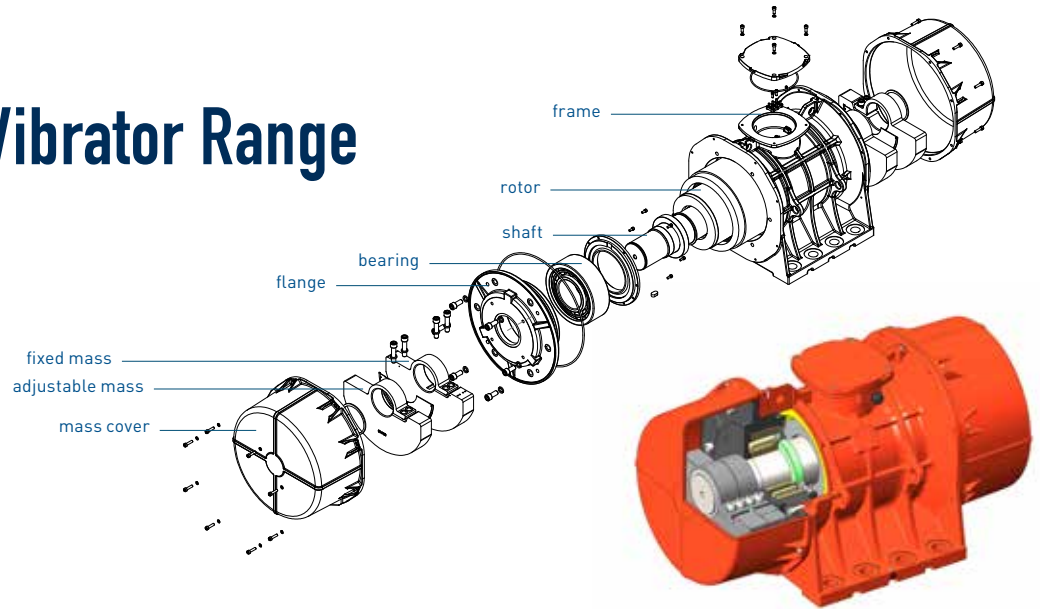

Providing centrifugal force up to 26,000 kgs and with multiple voltage options OLI's range of electric motovibrators covers several fields of application in every country as well as many different industrial sectors: from food to mining, from foundry to recycling and more. OLI's electric motovibrators are designed and manufactured using the latest technologies and premium quality materials and components. Vibrator bodies, bearing flanges and shafts are FMEA designed and manufactured using first grade Aluminium alloy, cast iron and steel alloy to withstand heavy duty

applications and guarantee safe operation in any condition. Vacuum impregnated windings and class F insulating materials enhance reliability and durability. Top quality bearings and an efficient grease retaining system assure long lasting performance and low noise generation. Adjustable eccentric masses allow easy fine tuning of the Max centrifugal force provided by the vibrator. Several certifications for use in hazardous environments are available in the OLI range to match the most demanding specification worldwide.

## ATEX ZONES

- ACCIDENTAL RISK
- OCCASIONAL RISK
- CONSTANT RISK

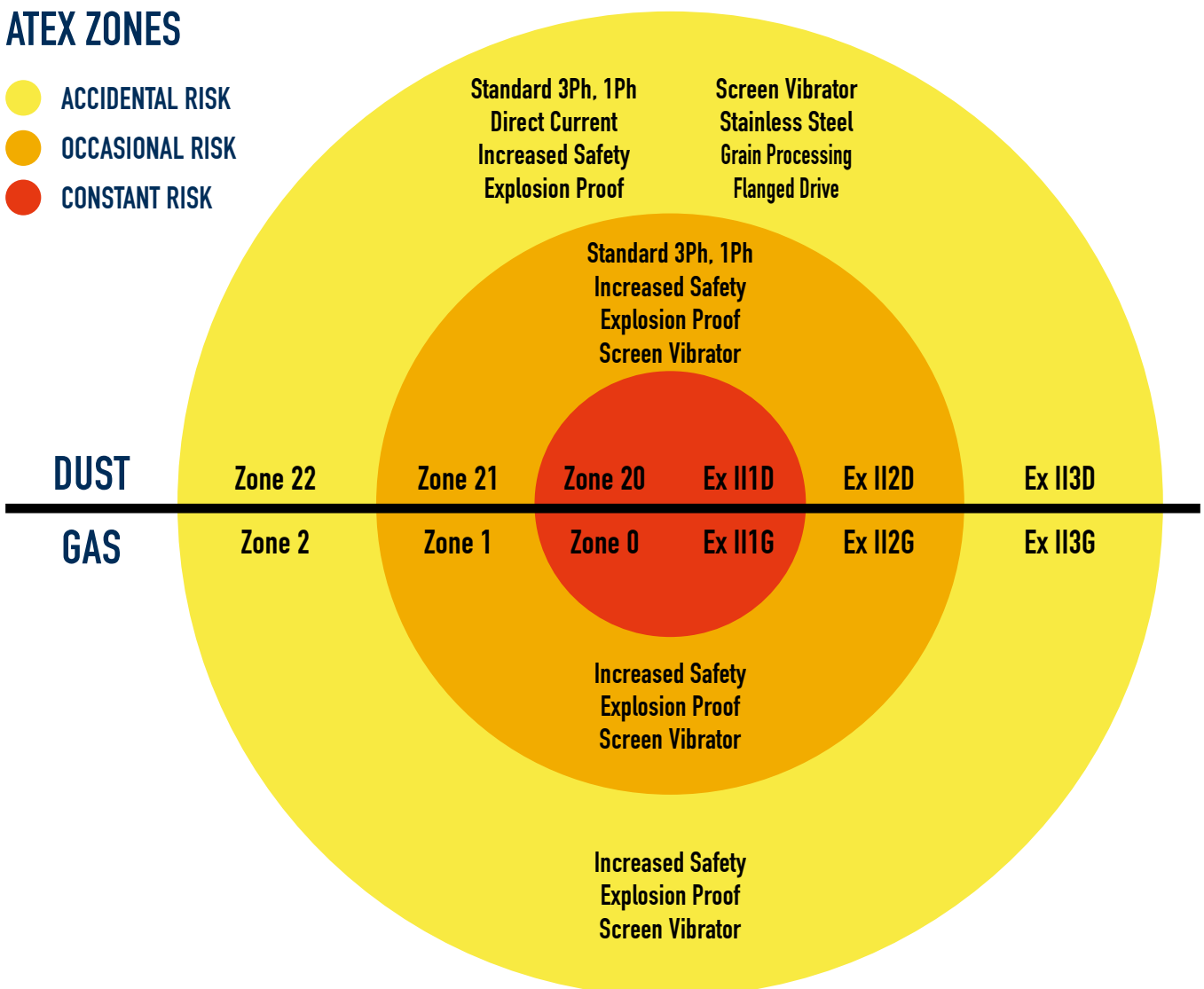





# Certifications

## Standard



Conformity with European Directive - Low voltage 2014/35/UE; Machine Directive 2006/42/EC; ATEX 2014/34/UE - UL 1836. UL 1004-1 - SAC22.2 NO 25. 100. 145

CATEGORY	CERTIFICATIONS	INTERNATIONAL STANDARD	GAS	DUST
ATEX zone 21 Class II Div.2 Temperature range -20/+40 °C *		EN 60079-0, EN 60079-31	n/a	II2D Ex tb IIIC Tx Db IP66
		IEC 60079-0, IEC 60079-31	n/a	Ex tb IIIC Tx Db IP66
		UL 1004-1, UL 60079-0, UL 60079-31 CSA 22.2 100, CSA 22.2 60079-0, CSA 22.2 60079-31	n/a	Class II Div.2 Groups F, G T4

\* Extended temperature range up to 55 °C available on request.

**MVE DC Range:** II3D Ex tc IIIC T100 IP66

Tx = T100 °C up to size 30 included;  
T135 °C from size 40 up.

## Grain Processing, Stainless Steel, Screen Vibrator and Flanged Drive



Conformity with European Directive - Low voltage 2014/35/UE; Machine Directive 2006/42/EC; ATEX 2014/34/UE

CATEGORY	CERTIFICATIONS	INTERNATIONAL STANDARD	GAS	DUST
ATEX zone 22 Temperature range -20/+40 °C		EN 60079-0, EN 60079-31	n/a	II3D Ex tc IIIC T100 IP66
		UL 1446, CSA C22.2 NO 0-10	n/a	n/a

## Increased Safety



Conformity with European Directive - Low voltage 2014/35/UE; Machine Directive 2006/42/EC; ATEX 2014/34/UE - UL 1836. UL 1004-1 - SAC22.2 NO 25. 100. 145

CATEGORY	CERTIFICATIONS	INTERNATIONAL STANDARD	GAS	DUST
ATEX zone 1-21 Class II Div.2 (dust) Class I Div.2 (gas) Temperature range -20/+40 °C		EN 60079-0, EN 60079-7	II 2G Ex eb IIC T3 Gb	II2D Ex tb IIIC Tx Db IP66
		IEC 60079-0, IEC 60079-7	Ex eb IIC T3 Gb	Ex tb IIIC Tx Db IP66
		UL 1004-1, UL 60079-0, UL 60079-7 CSA 22.2 100, CSA 22.2 60079-0, CSA 22.2 60079-7	Class I Div.2 Group A, B, C, D T3	Class II Div.2 Groups F, G T4

Tx = T100 °C up to size 30 included;  
T135 °C from size 40 up.

## Explosion Proof and Screen Vibrator



Conformity with European Directive - Low voltage 2014/35/UE; Machine Directive 2006/42/EC - ATEX 2014/34/UE - UL 1836. UL 1004-1. UL 674 - CSAC22.2 NO 25. 100. 145

CATEGORY	CERTIFICATIONS	INTERNATIONAL STANDARD	GAS	DUST
ATEX zone 1-21 Class I Div.1 Class II Div.1 ** Temperature range -20/+60 °C		EN 60079-0, EN 60079-31, EN 60079-1	ATEX II 2G Ex db IIB T4 Gb	ATEX II 2D Ex tb IIIC T135°C Db
		IEC 60079-0, IEC 60079-31, IEC 60079-1	IECEx Ex db IIB T4 Gb	IECEx Ex tb IIIC T135°C Db
		UL 1004-1, UL 1004-3, UL1203; UL674, CSA C22.2 No.145, CSA C22.2 No.30-M1986.	CLASS I Div.1 Group C, D T4 IP66	CLASS II Div.1 GROUP E,F,G**

\* Screen vibrator is also available with the same certifications as the standard, not explosion proof range, mentioned in the first chart of this page.

\*\* Soon available.



# How to choose a motovibrator

1.

Choose rpm and the amplitude "e" (0 - peak) suitable for your application:

Circular vibration

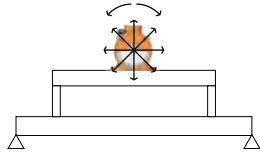

Linear vibration

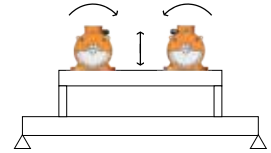

Application processes	Vibration		Revolutions Per Minute					
			50Hz	750	1000	1500	3000	6000
	Circular	Linear	60Hz	900	1200	1800	3600	-
Conveying		✓			✓	✓		
Separation / Screening / Sizing		✓		✓	✓	✓		
Positioning / Feeding		✓		✓	✓	✓		
Filter cleaning	✓						✓	
Silo/hopper emptying	✓						✓	
Fluid beds		✓		✓	✓			
Bin activators	✓					✓	✓	
Compacting		✓					✓	✓
Concrete consolidation	✓						✓	✓

rpm	e (mm)	
	Min.	Max.
3,600	0.3	0.6
3,000	0.3	0.8
1,800	1.2	2.2
1,500	1.4	2.6
1,200	2.5	4.0
1,000	3.0	5.2
900	3.5	5.5
750	3.5	6.0

2.

Choose an MVE from the tables of the following pages and use its  $W_m$  into this formula:

$$e = 5 \times \frac{n \times W_m}{n \times M_{mot} + M_{vm}}$$

$e$  = amplitude of vibration 0-peak (mm)  
 $n$  = number of vibrators  
 $W_m$  = working moment (kgcm)  
 $M_{mot}$  = vibrator weight (kg)  
 $M_{vm}$  = vibrating machine weight (without material and vibrators)

3.

Check the obtained value "e":

- If it is similar to the required one (step 1) → the MVE model is correct.
- If it is not similar to the required one (step 1) → repeat the process (step 2) with a different MVE model.

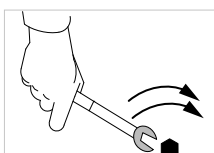

For tips on installation see page 44









# Standard Rated Voltages

Several voltages are available to match local electric specifications worldwide both at 50Hz and 60Hz.

All OLI vibrators can be operated with double voltage by simply changing the connections inside the terminal box from **Star** to **Delta** or vice-versa.

**As a general rule MVEs with rated power >4,3kW have standard Delta terminal box connection, with the only exception of MVE 5000/3E-75A1. Smaller MVEs have standard Star terminal box connection.** Refer to the product specification charts to see the factory setting for each model.

*For details about "Star" and "Delta" connections see page 45.*

	200-230/345-400 V	50/60 Hz
	220-240/380-415 V 380-415 V (Delta) *	50 Hz
	230/460 V * 460 V (Delta) *	60 Hz
	330/575 V * 575 V (Delta) * 460 V (Delta) *	60 Hz
	290-300/500-525 V 500-525 V (Delta)	50 Hz
	207-253/414-480 V	60 Hz
	220-240/380-415 V 220-277/380-480 V 380/415 V (Delta) 460 V (Delta) *	50 Hz 60 Hz 50 Hz 60 Hz

\* Voltage Tolerance:  $\pm 10\%$

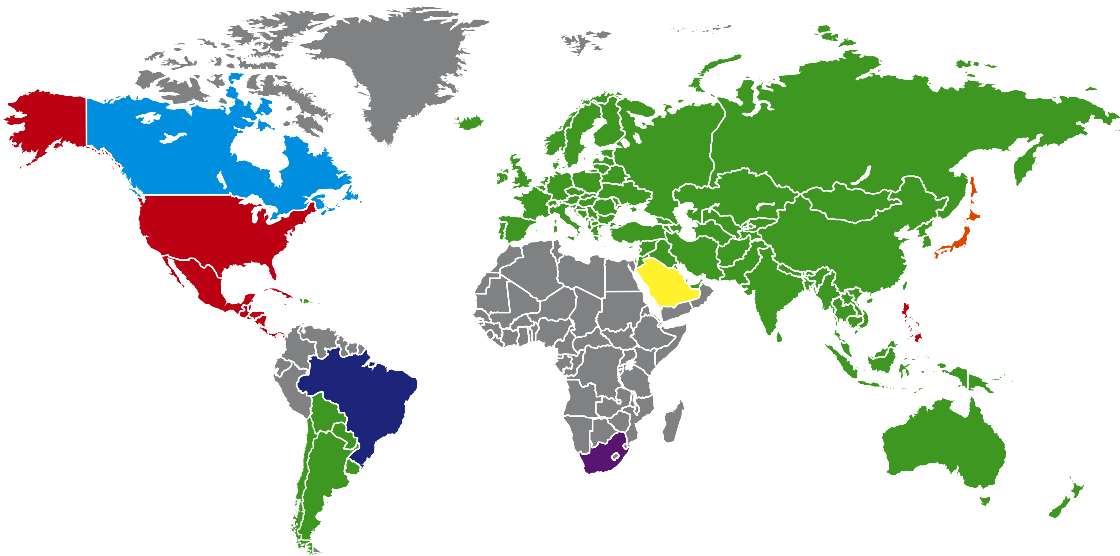

## Optionals



### STEEL-IT

Specifically developed for food applications featuring a special coating containing AiSi 316L stainless steel.



### STAINLESS STEEL COVERS

Available with clean finishing. AiSi 304 stainless steel mass covers (on request) for the most demanding applications. Available of to size 91.



### SPLIT COVERS

Developed for space saving applications. Available from size 60 and above.



### EXTENDED SHAFTS

Designed for multiple vibrator application. Available on request.



### HEATERS

To be used in severe cold environment.



### FOOTPRINT

Competitor's footprint available on request.

### IMPORTANT:

Rated voltage might change according to the certification level permitted when some optionals are chosen.



# MVE STANDARD RANGE



## 2 POLES - 3000/3600 rpm

Class II Div.2: Temp. Class T4  
ExII 2D Temp. Class: ● 100 °C ● 135 °C

\* Terminal Connections: Y High Voltage; ▲ Low Voltage

Wm (kgcm)		Model		Centrifugal Force (kg)		Weight (kg)		ELECTRICAL SPECIFICATIONS								
50Hz	60Hz	50Hz	60Hz	50Hz	60Hz	50Hz	60Hz	Input Power (kW)		Standard Nominal Current		* Terminal Connection	Ia/In		Cable Gland	
50Hz	60Hz	50Hz	60Hz	50Hz	60Hz	50Hz	60Hz	50Hz	60Hz	50Hz (400V)	60Hz (460V)		50Hz	60Hz	Metric	
1.3	1.0	MVE 60/3E-10A0	MVE 60/36E-10A0	66	71	4		0.09	0.09	0.25	0.23	Y	3.2	3.2	M16	●
2.0	1.3	MVE 100/3E-10A0	MVE 100/36E-10A0	98	95	5		0.09	0.09	0.25	0.23	Y	3.2	3.2	M16	●
3.7	2.6	MVE 200/3E-20A0	MVE 200/36E-20A0	187	189	7		0.15	0.18	0.35	0.30	Y	3.5	3.5	M20	●
3.7	2.6	MVE 200/3E-23A0	MVE 200/36E-23A0	187	189	7		0.15	0.18	0.35	0.30	Y	3.5	3.5	M20	●
6.4	4.5	MVE 300/3E-30A0	MVE 300/36E-30A0	321	323	10		0.25	0.28	0.52	0.45	Y	3.8	3.7	M20	●
8.0	5.7	MVE 400/3E-30A0	MVE 400/36E-30A0	407	411	10		0.27	0.33	0.58	0.60	Y	3.7	3.7	M20	●
10.3	7.4	MVE 500/3E-40A0	MVE 500/36E-40A0	530	534	16		0.50	0.58	0.96	0.97	Y	4.2	4.4	M20	●
14.9	10.6	MVE 700/3E-40A0	MVE 700/36E-40A0	758	765	17		0.59	0.61	1.25	1.24	Y	4.5	5.2	M20	●
15.7	11.1	MVE 800/3E-50A0	MVE 800/36E-50A0	794	800	20		0.70	0.84	1.45	1.50	Y	4.0	4.0	M20	●
20.3	14.0	MVE 1200/3E-50A0	MVE 1200/36E-50A0	1,005	1,013	21		0.95	1.15	1.85	1.95	Y	4.6	4.7	M20	●
26.6	18.6	MVE 1300/3E-50A0	MVE 1300/36E-50A0	1,355	1,365	22		1.30	1.38	2.44	2.25	Y	5.4	5.2	M20	●
31.3	22.2	MVE 1600/3E-60A0	MVE 1600/36E-60A0	1,601	1,608	51	50	1.54	1.60	2.94	2.61	Y	6.1	6.4	M25	●
36.8	27.6	MVE 2000/3E-60A0	MVE 2000/36E-60A0	2,027	1,997	52	50	2.10	2.10	3.75	3.42	Y	6.7	6.6	M25	●
46.0	31.9	MVE 2300/3E-60A0	MVE 2300/36E-60A0	2,302	2,306	53	51	2.40	2.45	4.44	3.45	Y	6.2	6.5	M25	●
68.1	43.9	MVE 3200/3E-75A1	MVE 3200/36E-75A1	3,252	3,176	103	101	2.76	2.90	5.30	4.61	Y	8.5	8.4	M32	●
79.4	56.0	MVE 4000/3E-75A1	MVE 4000/36E-75A1	4,033	4,052	107	104	2.90	2.90	5.30	4.61	Y	8.7	9.9	M32	●
103.2	69.8	MVE 5000/3E-75A1	MVE 5000/36E-75A1	5,009	5,048	111	106	4.00	4.00	7.22	6.28	Y	8.7	10.0	M32	●
129.6	90.5	MVE 6500/3E-85A0	MVE 6500/36E-85A0	6,510	6,552	228	230	5.23	5.50	9.43	8.20	▲	8.7	9.0	M32	●
179.6	129.6	MVE 9000/3E-85A0	MVE 9000/36E-85A0	9,025	9,375	240	235	9.50	9.30	17.80	14.40	▲	8.6	8.8	M32	●
129.6	90.5	MVE 6500/3E-86A0	MVE 6500/36E-86A0	6,510	6,552	228	230	5.50	6.30	9.50	9.50	▲	8.2	7.7	M32	●
179.6	129.6	MVE 9000/3E-86A0	MVE 9000/36E-86A0	9,025	9,375	240	235	6.60	7.70	11.50	11.50	▲	8.2	8.2	M32	●

SIZE 10A0



SIZE 60A0



SIZE 105A0



UP TO SIZE 60 (NOT INCLUDED)  
60Hz masses = 50Hz masses adjusted at 70%



ABOVE SIZE 60 (INCLUDED)  
Specific masses for 60Hz

To convert kg into Newton: N = 9.81 · kg



- » II2D Ex tb IIIC Tx Db IP66
- » Equipment and protective system intended for use in potentially explosive atmospheres [Zone 21] - Directive 2014/34/UE
- » Compliance with Essential Health and Safety Requirements
- » IEC 60034-1, IEC EN 60079-0, IEC EN 60079-31

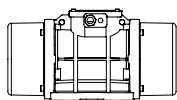

Model		Drawing	Size	DIMENSIONAL SPECIFICATIONS (mm)															
				C		M		A	B	Ø G	Holes	D	E	F	H	I	L	N	
50Hz	60Hz			50Hz	60Hz					n°									
MVE 60/3E-10A0	MVE 60/36E-10A0	A1	10A0	213	45	Multiple Footprint			4	130	135	11	50	96	107	85			
						62-74	106	9									33	83-102	7
MVE 100/3E-10A0	MVE 100/36E-10A0	A1	10A0	213	45	Multiple Footprint			4	130	135	11	50	96	107	85			
						62-74	106	9									33	83-102	7
MVE 200/3E-20A0	MVE 200/36E-20A0	B1	20A0	233	54	62-74	106	9	4	130	154	15	65	125	120	112			
MVE 200/3E-23A0	MVE 200/36E-23A0	G	23A0	222	55	Multiple Footprint			4	164	140	25	82	116	159	110			
						62-74	106	9									65	140	13
						115	135	11									135	115	11
						135	115	11											
MVE 300/3E-30A0	MVE 300/36E-30A0	C1	30A0	254	42	Multiple Footprint			4	150	173	15	79	150	166	134			
						80	110	11									90	125	13
						124	110	11									135	115	11
						135	115	11											
MVE 400/3E-30A0	MVE 400/36E-30A0	C1	30A0	274	52	Multiple Footprint			4	150	173	15	79	150	166	134			
						80	110	11									90	125	13
						124	110	11									135	115	11
						135	115	11											
MVE 500/3E-40A0	MVE 500/36E-40A0	D1	40A0	330	78	105	140	13	4	170	196	20	92	169	166	158			
MVE 700/3E-40A0	MVE 700/36E-40A0	D1	40A0	330	78	105	140	13	4	170	196	20	92	169	166	158			
MVE 800/3E-50A0	MVE 800/36E-50A0	D1	50A0	321	62	120	170	17	4	208	210	22	96	185	192	170			
MVE 1200/3E-50A0	MVE 1200/36E-50A0	D1	50A0	321	62	120	170	17	4	208	210	22	96	185	192	170			
MVE 1300/3E-50A0	MVE 1300/36E-50A0	D1	50A0	321	62	120	170	17	4	208	210	22	96	185	192	170			
MVE 1600/3E-60A0	MVE 1600/36E-60A0	D1	60A0	402	90	140	190	17	4	230	260	26	124	240	218	222			
MVE 2000/3E-60A0	MVE 2000/36E-60A0	D1	60A0	402	90	140	190	17	4	230	260	26	124	240	218	222			
MVE 2300/3E-60A0	MVE 2300/36E-60A0	D1	60A0	402	90	140	190	17	4	230	260	26	124	240	218	222			
MVE 3200/3E-75A1	MVE 3200/36E-75A1	D1	75A1	516	117	155	255	25	4	304	314	30	147	285	277	265			
MVE 4000/3E-75A1	MVE 4000/36E-75A1	D1	75A1	516	117	155	255	25	4	304	314	30	147	285	277	265			
MVE 5000/3E-75A1	MVE 5000/36E-75A1	D1	75A1	564	516	141	117	155	255	25	4	304	314	30	147	285	277	265	
MVE 6500/3E-85A0	MVE 6500/36E-85A0	D1	85A0	624	130	200	320	28	4	385	402	40	203	394	360	378			
MVE 9000/3E-85A0	MVE 9000/36E-85A0	D1	85A0	624	130	200	320	28	4	385	402	40	203	394	360	378			
MVE 6500/3E-86A0	MVE 6500/36E-86A0	D1	86A0	624	130	200	320	28	4	385	402	40	203	394	360	378			
MVE 9000/3E-86A0	MVE 9000/36E-86A0	D1	86A0	624	130	200	320	28	4	385	402	40	203	394	360	378			

Notes:

.....

.....

.....

NOTE: Dimensions with coarse degree of accuracy related to UNI 22768/1

This information is provided without warranty, representation, inducement or licence of any kind. It is accurate to the best OLI knowledge or is obtained from sources believed to be accurate. OLI therefore assumes no legal responsibility. The latest and most updated information are available online.



» Class II Div.2 Group F, G T4  
 » Conform to UL 1004-1, UL 1004-3, UL60079-31, UL60079-0, CSA 60079-0, CSA 60079-31, CSA 22.2 N°100, CSA 22.2 N°77

# MVE STANDARD RANGE



## 4 POLES - 1500/1800 rpm

Class II Div.2: Temp. Class **T4**  
ExII 2D Temp. Class: ● 100 °C ● 135 °C

\* Terminal Connections: **Y** High Voltage; **Δ** Low Voltage

Wm (Kgcm)		Model		Centrifugal Force (kg)		Weight (kg)		ELECTRICAL SPECIFICATIONS								
								Input Power (kW)		Standard Nominal Current		* Terminal Connection	Ia/In		Cable Gland	
50Hz	60Hz	50 Hz	60 Hz	50Hz	60Hz	50Hz	60Hz	50Hz	60Hz	50Hz (400V)	60Hz (460V)		50Hz	60Hz		Metric
2.0	2.0	MVE 40/15E-10A0	MVE 40/18E-10A0	25	36	5		0.05	0.04	0.31	0.31	Y	2.2	2.2	M16	●
6.0	4.2	MVE 90/15E-20A0	MVE 90/18E-20A0	75	76	7		0.07	0.08	0.31	0.25	Y	2.2	2.2	M20	●
7.7	5.4	MVE 100/15E-20A0	MVE 100/18E-20A0	97	98	7		0.07	0.08	0.31	0.25	Y	2.2	2.2	M20	●
15.4	10.8	MVE 200/15E-30A0	MVE 200/18E-30A0	194	196	12		0.12	0.15	0.49	0.50	Y	2.2	2.2	M20	●
33.4	23.4	MVE 400/15E-40A0	MVE 400/18E-40A0	420	423	20		0.27	0.32	0.84	0.86	Y	2.7	2.7	M20	●
40.1	28.1	MVE 500/15E-40A0	MVE 500/18E-40A0	504	508	21		0.35	0.40	1.06	1.09	Y	3.0	2.9	M20	●
26.6	18.6	MVE 300/15E-50A0	MVE 300/18E-50A0	334	336	22		0.62	0.73	1.32	1.20	Y	3.2	3.4	M20	●
56.8	39.4	MVE 700/15E-50A0	MVE 700/18E-50A0	714	712	27		0.62	0.73	1.32	1.20	Y	3.2	3.4	M20	●
56.8	39.4	MVE 710/15E-50A0	MVE 710/18E-50A0	714	712	27		0.62	0.73	1.32	1.20	Y	3.2	3.4	M20	●
75.6	52.9	MVE 950/15E-50A0	MVE 950/18E-50A0	950	957	33		0.64	0.77	1.40	1.35	Y	4.2	4.2	M20	●
87.7	61.4	MVE 1100/15E-51A0	MVE 1100/18E-51A0	1,102	1,110	35	28.5	0.64	0.77	1.40	1.35	Y	4.0	4.0	M20	●
108.6	76.7	MVE 1400/15E-60A0	MVE 1400/18E-60A0	1,364	1,388	63.5	60.5	0.70	0.84	1.78	1.78	Y	4.2	4.2	M25	●
137.3	92.0	MVE 1700/15E-60A0	MVE 1700/18E-60A0	1,725	1,664	67.5	64	1.13	1.30	2.16	2.09	Y	4.9	4.7	M25	●
187.7	137.4	MVE 2400/15E-60A0	MVE 2400/18E-60A0	2,358	2,485	77	69.5	1.57	1.88	3.20	3.20	Y	5.1	5.1	M25	●
203.5	135.6	MVE 2500/15E-70A0	MVE 2500/18E-70A0	2,557	2,454	85	74.4	1.76	2.00	3.08	3.00	Y	6.2	6.3	M25	●
248.7	169.8	MVE 3000/15E-70A0	MVE 3000/18E-70A0	3,124	3,071	83.5	78	1.90	2.30	3.68	3.30	Y	6.7	6.8	M25	●
306.7	204.7	MVE 3800/15E-75A0	MVE 3800/18E-75A0	3,853	3,704	125	113	2.20	2.60	4.15	4.15	Y	7.0	7.0	M32	●
343.2	240.9	MVE 4300/15E-75A0	MVE 4300/18E-75A0	4,312	4,359	136	120	2.50	3.00	4.50	4.60	Y	7.2	7.4	M32	●
437.4	303.7	MVE 5500/15E-80A0	MVE 5500/18E-80A0	5,495	5,495	181	169	2.88	3.45	6.50	5.50	Y	7.3	7.2	M32	●
576.8	397.3	MVE 7200/15E-85A0	MVE 7200/18E-85A0	7,246	7,188	237	231	4.00	4.80	8.50	8.70	Δ	7.0	7.1	M32	●
718.0	498.8	MVE 9000/15E-85A0	MVE 9000/18E-85A0	9,020	9,023	252	241	7.35	8.50	13.40	12.00	Δ	7.2	7.2	M32	●
579.9	406.0	MVE 7200/15E-86A0	MVE 7200/18E-86A0	7,286	7,345	237	231	6.00	6.50	11.00	10.80	Δ	4.7	4.5	M32	●
724.8	507.0	MVE 9000/15E-86A0	MVE 9000/18E-86A0	9,106	9,172	252	241	6.00	6.50	11.00	10.80	Δ	4.7	4.5	M32	●
800.1	588.3	MVE 10000/15E-90A0	MVE 10000/18E-90A0	10,052	10,643	300	286	5.40	7.00	13.00	13.00	Δ	6.7	6.6	M32	●
835.7	581.3	MVE 10000/15E-91A0	MVE 10000/18E-91A0	10,499	10,517	300	286	7.00	8.20	13.10	13.10	Δ	7.2	7.7	M32	●
939	655	MVE 11500/15E-100A0	MVE 11500/18E-100A0	11,779	11,853	445	422	9.00	10.00	15.50	15.50	Δ	7.0	7.0	M32	●
1,142	838	MVE 14500/15E-100A0	MVE 14500/18E-100A0	14,352	15,153	460	442	11.00	13.00	18.50	18.50	Δ	8.0	8.0	M32	●



**UP TO SIZE 60 (NOT INCLUDED)**  
60Hz masses = 50Hz masses adjusted at 70%  
Except for model MVE 1100/15 - 1100/18



**ABOVE SIZE 60 (INCLUDED)**  
Specific masses for 60Hz

To convert kg into Newton: **N = 9.81 · kg**



- » II2D Ex tb IIIC Tx Db IP66
- » Equipment and protective system intended for use in potentially explosive atmospheres [Zone 21] - Directive 2014/34/UE
- » Compliance with Essential Health and Safety Requirements
- » IEC 60034-1, IEC EN 60079-0, IEC EN 60079-31

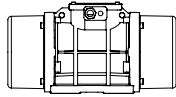

Technical drawings in the last page →

STANDARD

INCREASED SAFETY

EXPLOSION-PROOF

GRAIN PROCESSING

SCREEN VIBRATOR

STAINLESS STEEL

FLANGED DRIVE

Model		Drawing	Size	DIMENSIONAL SPECIFICATIONS (mm)														
				C		M		A	B	Ø G	Holes n°	D	E	F	H	I	L	N
				50Hz	60Hz	50Hz	60Hz											
MVE 40/15E-10A0	MVE 40/18E-10A0	A	10A0	213	45	Multiple Footprint 62-74 106 9 33 83-102 7			4	130	135	11	50	96	107	85		
MVE 90/15E-20A0	MVE 90/18E-20A0	B	20A0	233	54	62-74	106	9	4	130	154	15	65	125	120	112		
MVE 100/15E-20A0	MVE 100/18E-20A0	B	20A0	233	54	62-74	106	9	4	130	154	15	65	125	120	112		
MVE 200/15E-30A0	MVE 200/18E-30A0	C	30A0	274	52	Multiple Footprint 80 110 11 90 125 13 124 110 11 135 115 11			4	150	173	15	79	150	166	134		
MVE 400/15E-40A0	MVE 400/18E-40A0	D1	40A0	330	78	105	140	13	4	170	196	20	92	174	166	160		
MVE 500/15E-40A0	MVE 500/18E-40A0	D1	40A0	330	78	105	140	13	4	170	196	20	92	174	166	160		
MVE 300/15E-50A0	MVE 300/18E-50A0	D1	50A0	321	62	120	170	17	4	208	210	22	96	185	192	170		
MVE 700/15E-50A0	MVE 700/18E-50A0	D1	50A0	391	97	120	170	17	4	208	210	22	96	185	192	170		
MVE 710/15E-50A0	MVE 710/18E-50A0	D1	50A0	391	97	120	170	17	4	208	210	22	96	185	192	170		
MVE 950/15E-50A0	MVE 950/18E-50A0	D1	50A0	455	129	120	170	17	4	208	210	22	96	185	192	170		
MVE 1100/15E-51A0	MVE 1100/18E-51A0	D1	51A0	414	106	120	170	17	4	208	220	25	105	202	192	187		
MVE 1400/15E-60A0	MVE 1400/18E-60A0	D1	60A0	446	112	140	190	17	4	230	260	26	124	240	218	222		
MVE 1700/15E-60A0	MVE 1700/18E-60A0	D1	60A0	446	112	140	190	17	4	230	260	26	124	240	218	222		
MVE 2400/15E-60A0	MVE 2400/18E-60A0	D1	60A0	490	446	134	112	140	190	17	4	230	260	26	124	240	218	222
MVE 2500/15E-70A0	MVE 2500/18E-70A0	D1	70A0	501	123	155	225	22	4	275	290	30	140	256	250	236		
MVE 3000/15E-70A0	MVE 3000/18E-70A0	D1	70A0	535	501	140	123	155	225	22	4	275	290	30	140	256	250	236
MVE 3800/15E-75A0	MVE 3800/18E-75A0	D1	75A0	564	536	151	117	155	255	23.5	4	304	314	30	147	285	277	265
MVE 4300/15E-75A0	MVE 4300/18E-75A0	D1	75A0	584	564	151	141	155	255	23.5	4	304	314	30	147	285	277	265
MVE 5500/15E-80A0	MVE 5500/18E-80A0	D1	80A0	603	143	180	280	26	4	332	354	32	170	330	312	311		
MVE 7200/15E-85A0	MVE 7200/18E-85A0	D1	85A0	624	130	200	320	28	4	385	402	40	203	394	360	378		
MVE 9000/15E-85A0	MVE 9000/18E-85A0	D1	85A0	624	130	200	320	28	4	385	402	40	203	394	360	378		
MVE 7200/15E-86A0	MVE 7200/18E-86A0	D1	86A0	624	130	200	320	28	4	385	402	40	203	394	360	378		
MVE 9000/15E-86A0	MVE 9000/18E-86A0	D1	86A0	624	130	200	320	28	4	385	402	40	203	394	360	378		
MVE 10000/15E-90A0	MVE 10000/18E-90A0	E1	90A0	728	170	125	380	39	6	452	415	40	205	394	380	378		
MVE 10000/15E-91A0	MVE 10000/18E-91A0	E1	91A0	728	170	125	380	39	6	452	415	40	205	394	380	378		
MVE 11500/15E-100A0	MVE 11500/18E-100A0	E	100	890	210	140	440	45	6	530	484	37	232	446	470	424		
MVE 14500/15E-100A0	MVE 14500/18E-100A0	E	100	890	210	140	440	45	6	530	484	37	232	446	470	424		

NOTE: Dimensions with coarse degree of accuracy related to UNI 22768/1

This information is provided without warranty, representation, inducement or licence of any kind. It is accurate to the best OLI knowledge or is obtained from sources believed to be accurate. OLI therefore assumes no legal responsibility. The latest and most updated information are available online.



- » Class II Div.2 Group F, G T4
- » Conform to UL 1004-1, UL 1004-3, UL60079-31, UL60079-0, CSA 60079-0, CSA 60079-31, CSA 22.2 N°100, CSA 22.2 N°77



# MVE STANDARD RANGE



## 6 POLES - 1000/1200 rpm

Class II Div.2: Temp. Class T4  
ExII 2D Temp. Class: ● 100 °C ● 135 °C

\* Terminal Connections: Y High Voltage; ▲ Low Voltage

Wm (Kgcm)		Model		Centrifugal Force (kg)		Weight (kg)		ELECTRICAL SPECIFICATIONS								
50Hz	60Hz	50Hz	60Hz	50Hz	60Hz	50Hz	60Hz	Input Power (kW)		Standard Nominal Current		* Terminal Connection	Ia/In		Cable Gland	
								50Hz	60Hz	50Hz (400V)	60Hz (460V)		50Hz	60Hz	Metric	
9.5	6.6	MVE 50/1E-30A0	MVE 50/12E-30A0	53	53	10		0.12	0.14	0.30	0.40	Y	2.2	2.2	M20	●
18.8	13.2	MVE 100/1E-30A0	MVE 100/12E-30A0	105	106	11		0.12	0.14	0.30	0.40	Y	2.2	2.2	M20	●
33.5	23.4	MVE 200/1E-40A0	MVE 200/12E-40A0	187	188	19		0.15	0.18	0.65	0.63	Y	2.2	2.2	M20	●
56.9	39.9	MVE 300/1E-50A0	MVE 300/12E-50A0	318	320	26		0.25	0.30	0.67	0.64	Y	2.7	2.7	M20	●
91.9	64.3	MVE 500/1E-50A0	MVE 500/12E-50A0	513	517	34		0.55	0.40	1.22	1.15	Y	3.0	2.9	M20	●
91.9	91.9	MVE 510/1E-51A0	MVE 510/12E-51A0	513	739	35		0.55	0.40	1.22	1.15	Y	3.0	2.9	M20	●
137.4	108.6	MVE 800/1E-60A0	MVE 800/12E-60A0	767	873	60	58	0.75	0.80	1.42	1.32	Y	3.4	3.3	M25	●
187.7	137.3	MVE 1100/1E-60A0	MVE 1100/12E-60A0	1,048	1,104	70	72	0.75	0.80	1.42	1.32	Y	3.4	3.3	M25	●
284.8	196.5	MVE 1500/1E-60A0	MVE 1500/12E-60A0	1,590	1,580	84	73	0.90	1.08	1.80	2.00	Y	3.5	3.5	M25	●
299.6	203.5	MVE 1600/1E-70A0	MVE 1600/12E-70A0	1,673	1,636	90	79	0.90	1.08	2.40	2.30	Y	3.9	3.8	M25	●
373.1	248.7	MVE 2100/1E-70A0	MVE 2100/12E-70A0	2,083	2,000	105	91	1.50	1.80	3.00	3.20	Y	4.5	4.6	M25	●
467.4	306.7	MVE 2600/1E-75A0	MVE 2600/12E-75A0	2,610	2,466	146.5	126.5	1.96	2.10	4.10	4.00	Y	5.0	5.0	M32	●
540.3	379.7	MVE 3000/1E-75A0	MVE 3000/12E-75A0	3,017	3,053	155	138	2.20	2.40	4.50	4.30	Y	5.2	5.2	M32	●
702.5	465.6	MVE 3700/1E-75A0	MVE 3700/12E-75A0	3,797	3,744	159	142	2.20	2.40	4.50	4.30	Y	5.2	5.2	M32	●
680.4	437.4	MVE 3800/1E-80A0	MVE 3800/12E-80A0	3,799	3,517	216	195	2.50	3.00	5.50	5.30	Y	6.1	6.2	M32	●
838.3	584.2	MVE 4700/1E-80A0	MVE 4700/12E-80A0	4,681	4,697	220	201	3.20	3.90	6.50	6.95	Y	5.7	5.9	M32	●
936.4	/	MVE 5200/1E-80A0	/	5,228	/	236	/	3.20	/	6.50	/	Y	5.7	/	M32	●
929.9	654.6	MVE 5200/1E-85A0	MVE 5200/12E-85A0	5,192	5,263	264	248	3.80	4.00	6.92	6.36	Y	5.7	5.7	M32	●
1,165.2	824.0	MVE 6500/1E-85A0	MVE 6500/12E-85A0	6,506	6,625	288	265	4.30	5.00	7.76	7.81	Y	6.4	6.2	M32	●
1,436.0	929.8	MVE 8000/1E-85A0	MVE 8000/12E-85A0	8,018	7,476	309	274	5.50	6.60	12.60	11.60	▲	6.2	6.4	M32	●
1,600.4	1,165.2	MVE 9000/1E-85A0	MVE 9000/12E-85A0	8,936	9,369	322	291	6.20	7.45	13.20	12.60	▲	6.5	6.4	M32	●
1,434.0	929.8	MVE 8000/1E-86A0	MVE 8000/12E-86A0	8,007	7,476	309	274	4.60	5.50	9.00	10.00	▲	6.0	6.2	M32	●
1,598.0	1,165.2	MVE 9000/1E-86A0	MVE 9000/12E-86A0	8,923	9,369	322	291	4.60	5.50	9.00	10.00	▲	6.0	6.2	M32	●
1,788.4	1,240.0	MVE 10000/1E-90A0	MVE 10000/12E-90A0	9,986	9,970	374	348	6.10	6.40	14.00	12.70	▲	6.6	6.6	M32	●
2,329.8	1,647.4	MVE 13000/1E-90A0	MVE 13000/12E-90A0	13,009	13,246	411	364	7.50	8.30	16.40	16.00	▲	6.4	6.5	M32	●
1,802.9	1,240.0	MVE 10000/1E-91A0	MVE 10000/12E-91A0	10,067	9,970	373	348	6.40	7.70	13.00	14.50	▲	6.0	6.0	M32	●
2,056.9	1,433.0	MVE 11400/1E-91A0	MVE 11400/12E-91A0	11,485	11,522	404	361	6.40	7.70	13.00	14.50	▲	6.0	6.0	M32	●
2,311.0	1,647.4	MVE 13000/1E-91A0	MVE 13000/12E-91A0	12,904	13,246	440	393	8.00	8.90	17.20	18.10	▲	5.6	6.3	M32	●
2,253	1,550	MVE 12000/1E-100A0	MVE 12000/12E-100A0	12,580	12,466	522	476	8.00	9.50	15.00	15.00	▲	5.0	5.5	M32	●
2,634	1,856	MVE 15000/1E-105A0	MVE 15000/12E-105A0	14,706	14,923	672	630	10.10	12.00	18.00	18.00	▲	5.8	5.8	M32	●
3,220	2,147	MVE 17500/1E-105A0	MVE 17500/12E-105A0	17,980	17,264	744	684	11.90	14.20	21.00	21.00	▲	5.6	5.9	M32	●
3,632	2,525	MVE 19500/1E-105A0	MVE 19500/12E-105A0	20,285	20,299	768	728	12.00	14.50	24.00	24.00	▲	5.4	5.6	M32	●
4,067	2,622	MVE 22000/1E-110A0	MVE 22000/12E-110A0	22,711	21,079	916	868	13.90	17.00	28.00	28.00	▲	4.8	5.3	M32	●
4,572	3,163	MVE 25000/1E-110A0	MVE 25000/12E-110A0	25,532	25,432	994	937	13.90	17.00	28.00	28.00	▲	4.8	5.3	M32	●



UP TO SIZE 60 (NOT INCLUDED)  
60Hz masses = 50Hz masses adjusted at 70%



ABOVE SIZE 60 (INCLUDED)  
Specific masses for 60Hz

To convert kg into Newton: N = 9.81 · kg



- » II2D Ex tb IIIC Tx Db IP66
- » Equipment and protective system intended for use in potentially explosive atmospheres [Zone 21] - Directive 2014/34/UE
- » Compliance with Essential Health and Safety Requirements
- » IEC 60034-1, IEC EN 60079-0, IEC EN 60079-31



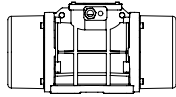

Technical drawings in the last page →

STANDARD

INCREASED SAFETY

EXPLOSION-PROOF

GRAIN PROCESSING

SCREEN VIBRATOR

STAINLESS STEEL

FLANGED DRIVE

Model		Drawing	Size	DIMENSIONAL SPECIFICATIONS (mm)														
				C		M		A	B	ØG	Holes	D	E	F	H	I	L	N
50Hz	60Hz	50Hz	60Hz	n°														
MVE 50/1E-30A0	MVE 50/12E-30A0	C	30A0	274	52	Multiple Footprint 80 110 11 90 125 13 124 110 11 135 115 11			4	150	173	15	79	150	166	134		
MVE 100/1E-30A0	MVE 100/12E-30A0	C	30A0	304	67	Multiple Footprint 80 110 11 90 125 13 124 110 11 135 115 11			4	150	173	15	79	150	166	134		
MVE 200/1E-40A0	MVE 200/12E-40A0	D1	40A0	330	78	105	140	13	4	170	196	20	92	174	166	160		
MVE 300/1E-50A0	MVE 300/12E-50A0	D1	50A0	391	97	120	170	17	4	208	210	22	96	185	192	170		
MVE 500/1E-50A0	MVE 500/12E-50A0	D1	50A0	455	129	120	170	17	4	208	210	22	96	185	192	170		
MVE 510/1E-51A0	MVE 510/12E-51A0	D1	51A0	455	129	120	170	17	4	208	210	22	96	185	192	170		
MVE 800/1E-60A0	MVE 800/12E-60A0	D1	60A0	446	112	140	190	17	4	230	260	26	124	240	218	222		
MVE 1100/1E-60A0	MVE 1100/12E-60A0	D1	60A0	490	446	134	112	140	190	17	4	230	260	26	124	240	218	222
MVE 1500/1E-60A0	MVE 1500/12E-60A0	D1	60A0	566	490.0	172	134	140	190	17	4	230	260	26	124	240	218	222
MVE 1600/1E-70A0	MVE 1600/12E-70A0	D1	70A0	563	501	154	123	155	225	22	4	275	290	30	140	256	250	236
MVE 2100/1E-70A0	MVE 2100/12E-70A0	D1	70A0	623	563	184	154	155	225	22	4	275	290	30	140	256	250	236
MVE 2600/1E-75A0	MVE 2600/12E-75A0	D1	75A0	692	584	205	151	155	255	23.5	4	304	314	30	147	285	277	265
MVE 3000/1E-75A0	MVE 3000/12E-75A0	D1	75A0	692	205	155	255	23.5	4	304	314	30	147	285	277	265		
MVE 3700/1E-75A0	MVE 3700/12E-75A0	D1	75A0	734	692	226	205	155	255	23.5	4	304	314	30	147	285	277	265
MVE 3800/1E-80A0	MVE 3800/12E-80A0	D1	80A0	683	603	183	143	180	280	26	4	332	354	32	170	330	312	311
MVE 4700/1E-80A0	MVE 4700/12E-80A0	D1	80A0	733	683	208	183	180	280	26	4	332	354	32	170	330	312	311
MVE 5200/1E-80A0	/	D1	80A0	733	/	208	/	180	280	26	4	332	354	32	170	330	312	311
MVE 5200/1E-85A0	MVE 5200/12E-85A0	D1	85A0	704	624	170.0	130.0	200	320	28	4	385	402	40	203	394	360	378
MVE 6500/1E-85A0	MVE 6500/12E-85A0	D1	85A0	704	170	200	320	28	4	385	402	40	203	394	360	378		
MVE 8000/1E-85A0	MVE 8000/12E-85A0	D1	85A0	774	704	205	170	200	320	28	4	385	402	40	203	394	360	378
MVE 9000/1E-85A0	MVE 9000/12E-85A0	D1	85A0	774	704	205	170	200	320	28	4	385	402	40	203	394	360	378
MVE 8000/1E-86A0	MVE 8000/12E-86A0	D1	86A0	774	205	200	320	28	4	385	402	40	203	394	360	378		
MVE 9000/1E-86A0	MVE 9000/12E-86A0	D1	86A0	774	205	200	320	28	4	385	402	40	203	394	360	378		
MVE 10000/1E-90A0	MVE 10000/12E-90A0	E1	90A0	908	798	260	205	125	380	39	6	452	415	40	205	394	380	378
MVE 13000/1E-90A0	MVE 13000/12E-90A0	E1	90A0	948	798	280	205	125	380	39	6	452	415	40	205	394	380	378
MVE 10000/1E-91A0	MVE 10000/12E-91A0	E1	91A0	908	260	125	380	39	6	452	415	40	205	394	380	378		
MVE 11400/1E-91A0	MVE 11400/12E-91A0	E1	91A0	908	260	125	380	39	6	452	415	40	205	394	380	378		
MVE 13000/1E-91A0	MVE 13000/12E-91A0	E1	91A0	948	280	125	380	39	6	452	415	40	205	394	380	378		
MVE 12000/1E-100A0	MVE 12000/12E-100A0	E	100	1,020	275	140	440	45	6	530	484	37	232	446	470	424		
MVE 15000/1E-105A0	MVE 15000/12E-105A0	H	105	980	210	140	480	45	8	570	542	48	268	510	560	490		
MVE 17500/1E-105A0	MVE 17500/12E-105A0	H	105	1,060	250	140	480	45	8	570	542	48	268	510	560	490		
MVE 19500/1E-105A0	MVE 19500/12E-105A0	H	105	1,060	250	140	480	45	8	570	542	48	268	510	560	490		
MVE 22000/1E-110A0	MVE 22000/12E-110A0	H	110	1,130	285	140	520	45	8	610	594	42	297	560	560	530		
MVE 25000/1E-110A0	MVE 25000/12E-110A0	H	110	1,130	285	140	520	45	8	610	594	42	297	560	560	530		

NOTE: Dimensions with coarse degree of accuracy related to UNI 22768/1

This information is provided without warranty, representation, inducement or licence of any kind. It is accurate to the best OLI knowledge or is obtained from sources believed to be accurate. OLI therefore assumes no legal responsibility. The latest and most updated information are available online.



- » Class II Div.2 Group F, G T4
- » Conform to UL 1004-1, UL 1004-3, UL60079-31, UL60079-0, CSA 60079-0, CSA 60079-31, CSA 22.2 N°100, CSA 22.2 N°77

# MVE STANDARD RANGE

## 8 POLES - 750/900 rpm



Class II Div.2: Temp. Class **T4**  
 ExII 2D Temp. Class: ● 100 °C ● 135 °C

\* Terminal Connections: **Y** High Voltage; **Δ** Low Voltage

Wm (Kgcm)		Model		Centrifugal Force (kg)		Weight (kg)		ELECTRICAL SPECIFICATIONS								
								Input Power (kW)		Standard Nominal Current		* Terminal Connection	Ia/In		Cable Gland	
50Hz	60Hz	50Hz	60Hz	50Hz	60Hz	50Hz	60Hz	50Hz (400V)	60Hz (460V)	Y	50Hz		60Hz	Metric		
33.4		MVE 150/075E-40A0	MVE 150/090E-40A0	105	151	21		0.23	0.25	1.14	1.14	Y	1.7	1.7	M20	●
56.9		MVE 250/075E-50A0	MVE 250/090E-50A0	179	257	29		0.25	0.30	0.90	0.89	Y	1.9	1.9	M20	●
84.0		MVE 400/075E-51A0	MVE 400/090E-51A0	264	380	34		0.25	0.30	0.90	0.89	Y	2.1	2.1	M20	●
137.3		MVE 650/075E-60A0	MVE 650/090E-60A0	431	621	63		0.37	0.45	1.20	1.20	Y	2.4	2.4	M25	●
187.7		MVE 900/075E-60A0	MVE 900/090E-60A0	589	849	70		0.55	0.54	1.23	1.29	Y	2.7	2.7	M25	●
299.6		MVE 1300/075E-70A0	MVE 1300/090E-70A0	941	1,355	90		0.75	0.90	2.20	2.20	Y	3.2	3.2	M25	●
467.4		MVE 2100/075E-75A0	MVE 2100/090E-75A0	1,468	2,114	150		1.00	1.20	2.81	2.89	Y	4.4	4.3	M32	●
680.3		MVE 3100/075E-80A0	MVE 3100/090E-80A0	2,137	3,077	201		2.00	2.30	4.50	4.40	Y	4.2	4.2	M32	●
838.4		MVE 3800/075E-80A0	MVE 3800/090E-80A0	2,633	3,792	219		2.50	3.00	6.00	6.00	Y	4.1	4.2	M32	●
929.7		MVE 4200/075E-85A0	MVE 4200/090E-85A0	2,920	4,205	268		2.90	3.40	6.50	6.50	Y	4.0	3.9	M32	●
1,165.2		MVE 5300/075E-85A0	MVE 5300/090E-85A0	3,660	5,270	289		3.70	4.30	8.00	8.20	Y	4.0	4.4	M32	●
1,435.9		MVE 6500/075E-85A0	MVE 6500/090E-85A0	4,510	6,494	308		3.80	4.20	8.78	8.30	Y	3.8	4.2	M32	●
2,200.4		MVE 10000/075E-90A0	MVE 10000/090E-90A0	6,911	9,952	422		6.80	7.50	13.50	12.50	Δ	3.7	4.4	M32	●
2,311.0		MVE 10000/075E-91A0	MVE 10000/090E-91A0	7,258	10,452	422		6.00	7.00	14.40	14.00	Δ	4.7	4.7	M32	●
2,835	2,553	MVE 12000/075E-100A0	MVE 12000/090E-100A0	8,904	11,546	571	553	7.50	8.00	13.50	13.50	Δ	3.8	4.0	M32	●
3,713	3,220	MVE 14000/075E-105A0	MVE 14000/090E-105A0	11,661	14,563	751	725	9.00	10.60	19.00	19.00	Δ	4.5	5.0	M32	●
4,401	3,920	MVE 17000/075E-105A0	MVE 17000/090E-105A0	13,822	17,729	812	792	9.10	11.00	20.00	20.00	Δ	5.3	5.8	M32	●
5,857	4,999	MVE 22000/075E-110A0	MVE 22000/090E-110A0	18,395	22,610	982	937	13.80	16.50	28.00	28.00	Δ	5.6	5.2	M32	●
6,662	5,857	MVE 26000/075E-110A0	MVE 26000/090E-110A0	20,924	26,489	1,016	982	13.80	16.50	28.00	28.00	Δ	5.6	5.2	M32	●

SIZE 40A0



SIZE 50A0



SIZE 60A0



**UP TO SIZE 90 (INCLUDED)**  
 60Hz masses = 50Hz masses adjusted at 100%



**ABOVE SIZE 90 (NOT INCLUDED)**  
 Specific masses for 60Hz

To convert kg into Newton: **N = 9.81 · kg**



- » II2D Ex tb IIIC Tx Db IP66
- » Equipment and protective system intended for use in potentially explosive atmospheres (Zone 21) - Directive 2014/34/UE
- » Compliance with Essential Health and Safety Requirements
- » IEC 60034-1, IEC EN 60079-0, IEC EN 60079-31

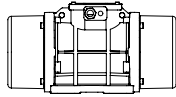

Technical drawings in the last page →

DIMENSIONAL SPECIFICATIONS (mm)

Model		Drawing	Size	DIMENSIONAL SPECIFICATIONS (mm)												
				C	M	A	B	Ø G	Holes n°	D	E	F	H	I	L	N
50Hz	60Hz			50Hz-60Hz	50Hz-60Hz											
MVE 150/075E-40A0	MVE 150/090E-40A0	D1	40A0	330	78	105	140	13	4	170	196	20	92	174	166	160
MVE 250/075E-50A0	MVE 250/090E-50A0	D1	50A0	391	97	120	170	17	4	208	210	22	96	185	192	170
MVE 400/075E-51A0	MVE 400/090E-51A0	D1	51A0	455	129	120	170	17	4	208	210	22	96	185	192	170
MVE 650/075E-60A0	MVE 650/090E-60A0	D1	60A0	446	112	140	190	17	4	230	260	26	124	240	218	222
MVE 900/075E-60A0	MVE 900/090E-60A0	D1	60A0	490	134	140	190	17	4	230	260	26	124	240	218	222
MVE 1300/075E-70A0	MVE 1300/090E-70A0	D1	70A0	563	154	155	225	22	4	275	290	30	140	256	250	236
MVE 2100/075E-75A0	MVE 2100/090E-75A0	D1	75A0	692	205	155	255	23.5	4	304	314	30	147	285	277	265
MVE 3100/075E-80A0	MVE 3100/090E-80A0	D1	80A0	683	183	180	280	26	4	332	354	32	170	330	312	311
MVE 3800/075E-80A0	MVE 3800/090E-80A0	D1	80A0	733	208	180	280	26	4	332	354	32	170	330	312	311
MVE 4200/075E-85A0	MVE 4200/090E-85A0	D1	85A0	704	170	200	320	28	4	385	402	40	203	394	360	378
MVE 5300/075E-85A0	MVE 5300/090E-85A0	D1	85A0	704	170	200	320	28	4	385	402	40	203	394	360	378
MVE 6500/075E-85A0	MVE 6500/090E-85A0	D1	85A0	774	205	200	320	28	4	385	402	40	203	394	360	378
MVE 10000/075E-90A0	MVE 10000/090E-90A0	E1	90A0	948	280	125	380	39	6	452	415	40	205	394	380	378
MVE 10000/075E-91A0	MVE 10000/090E-91A0	E1	91A0	948	280	125	380	39	6	452	415	40	205	394	380	378
MVE 12000/075E-100A0	MVE 12000/090E-100A0	E	100	1,020	275	140	440	45	6	530	484	37	232	446	470	424
MVE 14000/075E-105A0	MVE 14000/090E-105A0	H	105	1,060	250	140	480	45	8	570	542	48	268	510	560	490
MVE 17000/075E-105A0	MVE 17000/090E-105A0	H	105	1,120	280	140	480	45	8	570	542	48	268	510	560	490
MVE 22000/075E-110A0	MVE 22000/090E-110A0	H	110	1,130	285	140	520	45	8	610	594	42	297	560	560	530
MVE 26000/075E-110A0	MVE 26000/090E-110A0	H	110	1,130	285	140	520	45	8	610	594	42	297	560	560	530

Notes:

.....

.....

.....

.....

NOTE: Dimensions with coarse degree of accuracy related to UNI 22768/1

This information is provided without warranty, representation, inducement or licence of any kind. It is accurate to the best OLI knowledge or is obtained from sources believed to be accurate. OLI therefore assumes no legal responsibility. The latest and most updated information are available online.



- » Class II Div.2 Group F, G T4
- » Conform to UL 1004-1, UL 1004-3, UL60079-31, UL60079-0, CSA 60079-0, CSA 60079- 31, CSA 22.2 N°100, CSA 22.2 N°77

STANDARD

INCREASED SAFETY

EXPLOSION-PROOF

GRAIN PROCESSING

SCREEN VIBRATOR

STAINLESS STEEL

FLANGED DRIVE



# MVE STANDARD RANGE



## 2 POLES SINGLE-PHASE - 3000/3600 rpm

Class II Div.2: Temp. Class **T4**  
ExII 2D Temp. Class: ● 100 °C ● 135 °C

\* Terminal Connections: **Y** High Voltage; **▲** Low Voltage

Wm (KgcM)		Model		Centrifugal Force (kg)		Weight (kg)		ELECTRICAL SPECIFICATIONS							
								Input Power (kW)		Nominal Current A max		Cable Gland Metric	Capacitor *		
50Hz	60Hz	50Hz	60Hz	50Hz	60Hz	50Hz	60Hz	50Hz (230V)	60Hz (115V)	M16	50Hz (230V)		60Hz (115V)	●	
1.3	1.0	MVE 60/3E-10A0-M	MVE 60/36E-10A0-M	66	71	4		0.08	0.09		0.43	1.03	M16		3.0
2.0	1.3	MVE 100/3E-10A0-M	MVE 100/36E-10A0-M	98	95	5		0.10	0.11	0.54	1.30	M16	4.0	8.0	●
3.7	2.6	MVE 200/3E-20A0-M	MVE 200/36E-20A0-M	187	189	7		0.18	0.21	1.14	2.62	M20	8.0	16.0	●
3.7	2.6	MVE 200/3E-23A0-M	MVE 200/36E-23A0-M	187	189	7		0.18	0.21	1.14	2.62	M20	8.0	16.0	●
6.4	4.5	MVE 300/3E-30A0-M	MVE 300/36E-30A0-M	321	323	10		0.27	0.28	1.58	3.43	M20	12.5	25.0	●

\* NOTE: Capacitor not supplied with vibrator (to be ordered separately)

SIZE 10A0



SIZE 20A0



SIZE 30A0



To convert kg into Newton: **N = 9.81 · kg**



- » II2D Ex tb IIIC Tx Db IP66
- » Equipment and protective system intended for use in potentially explosive atmospheres (Zone 21) - Directive 2014/34/UE
- » Compliance with Essential Health and Safety Requirements
- » IEC 60034-1, IEC EN 60079-0, IEC EN 60079-31

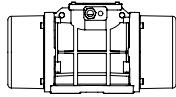

Technical drawings in the last page →

Model		Drawing	Size	DIMENSIONAL SPECIFICATIONS (mm)														
				C		M		A	B	Ø G	Holes n°	D	E	F	H	I	L	N
50Hz	60Hz			50Hz	60Hz	50Hz	60Hz											
MVE 60/3E-10A0-M	MVE 60/36E-10A0-M	A1	10A0	213	45	Multiple Footprint 62-74 106 9 33 83-102 7			4	130	135	11	50	96	107	85		
MVE 100/3E-10A0-M	MVE 100/36E-10A0-M	A1	10A0	213	45	Multiple Footprint 62-74 106 9 33 83-102 7			4	130	135	11	50	96	107	85		
MVE 200/3E-20A0-M	MVE 200/36E-20A0-M	B1	20A0	233	54	62-74	106	9	4	130	154	15	65	125	120	112		
MVE 200/3E-23A0-M	MVE 200/36E-23A0-M	G	23A0	222	55	Multiple Footprint 62-74 106 9 65 140 13 115 135 11 135 115 11			4	164	140	25	82	116	159	110		
MVE 300/3E-30A0-M	MVE 300/36E-30A0-M	C1	30A0	254	42	Multiple Footprint 80 110 11 90 125 13 124 110 11 135 115 11			4	154	173	15	79	150	166	134		

Notes:

.....

.....

.....

.....

NOTE: Dimensions with coarse degree of accuracy related to UNI 22768/1

This information is provided without warranty, representation, inducement or licence of any kind. It is accurate to the best OLI knowledge or is obtained from sources believed to be accurate. OLI therefore assumes no legal responsibility. The latest and most updated information are available online.



- » Class II Div.2 Group F, G T4
- » Conform to UL 1004-1, UL 1004-3, UL60079-31, UL60079-0, CSA 60079-0, CSA 60079- 31, CSA 22.2 N°100, CSA 22.2 N°77

STANDARD

INCREASED SAFETY

EXPLOSION-PROOF

GRAIN PROCESSING

SCREEN VIBRATOR

STAINLESS STEEL

FLANGED DRIVE

# MVE STANDARD RANGE

## MVE-MICRO - 3000/3600 rpm



Class II Div.2: Temp. Class **T4**  
 II 3D Temp. Class: ● 100 °C ● 135 °C

\* Terminal Connections: **Y** High Voltage; **▲** Low Voltage

### THREE-PHASE

Wm (kgcm)		Model		Centrifugal Force (kg)		Weight (kg)		ELECTRICAL SPECIFICATIONS					
								Input Power (kW)		Nominal Current A max			* Terminal Connection
50Hz	60Hz	50Hz	60Hz	50Hz	60Hz	50Hz	60Hz	50Hz (230V)	50Hz (400V)	60Hz (460V)	Metric		
0.4	0.4	MVE 21/3E-MICRO	MVE 21/36E-MICRO	20	29	2	0.04	0.04	0.21	0.12	0.12	Y	M16 ●
0.9	0.9	MVE 41/3E-MICRO	MVE41/36E-MICRO	45	65	2	0.06	0.06	0.30	0.18	0.18	Y	M16 ●

### SINGLE-PHASE

Wm (kgcm)		Model		Centrifugal Force (kg)		Weight (kg)		ELECTRICAL SPECIFICATIONS			
								Input Power (kW)		Nominal Current A max	
50Hz	60Hz	50Hz	60Hz	50Hz	60Hz	50Hz	60Hz	50Hz (230V)	60Hz (115V)	Metric	
0.1	0.1	MVE 3/3E-MICRO-M	MVE 3/36E-MICRO-M	4	6	1.6	0.03	0.04	0.30	0.80	M16 ●
0.1	0.1	MVE 6/3E-MICRO-M	MVE 6/36E-MICRO-M	6	9	1.6	0.03	0.04	0.30	0.80	M16 ●
0.4	0.4	MVE 21/3E-MICRO-M	MVE 21/36E-MICRO-M	20	29	2	0.04	0.07	0.20	0.80	M16 ●
0.9	0.9	MVE 41/3E-MICRO-M	MVE 41/36E-MICRO-M	45	65	2.4	0.05	0.07	0.25	0.80	M16 ●

MICRO



NOTE: Capacitor integrated in the cable

To convert kg into Newton: **N = 9.81 · kg**



- » II2D Ex tb IIIC Tx Db IP66
- » Equipment and protective system intended for use in potentially explosive atmospheres (Zone 21) - Directive 2014/34/UE
- » Compliance with Essential Health and Safety Requirements
- » IEC 60034-1, IEC EN 60079-0, IEC EN 60079-31

F

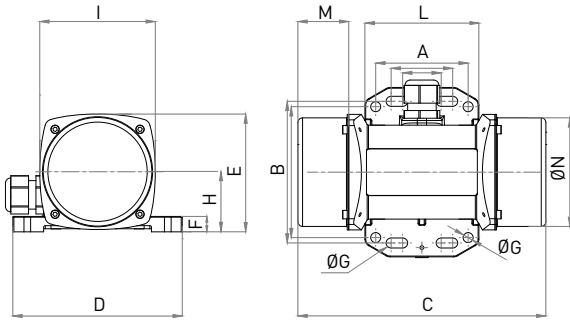

I

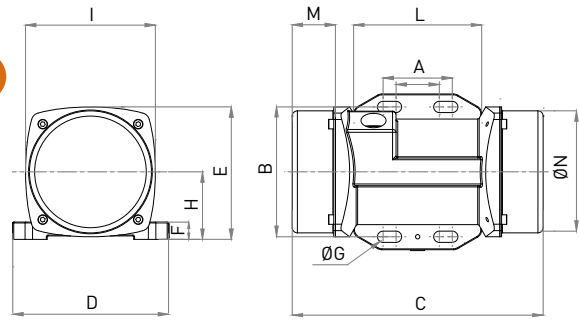

DIMENSIONAL SPECIFICATIONS (mm)

Model		Drawing	C	M	A	B	Ø G	Holes	D	E	F	H	I	L	N
50Hz	60Hz		50Hz	50Hz	Multiple Footprint			N°							
MVE 21/3E-MICRO	MVE21/36E-MICRO	F	145	25	25-40 60	92 85	6.5 6.5	4	110	76	10	39	75	74	70
MVE 41/3E-MICRO	MVE 41/36E-MICRO	F	161	33	25-40 60	92 85	6.5 6.5	4	110	76	10	39	75	74	70

DIMENSIONAL SPECIFICATIONS (mm)

Model		Drawing	C	M	A	B	Ø G	Holes	D	E	F	H	I	L	N
50Hz	60Hz		50Hz	50Hz	Multiple Footprint			N°							
MVE 3/3E-MICRO-M	MVE 3/36E-MICRO-M	F	145	25	25-40 60	92 85	6.5 6.5	4	110	76	10	39	75	74	70
MVE 6/3E-MICRO-M	MVE 6/36E-MICRO-M	I	145	25	25-40 -	75 -	6.5 -	4	90	76	10	39	75	74	70
MVE 21/3E-MICRO-M	MVE 21/36E-MICRO-M	F	145	25	25-40 60	92 85	6.5 6.5	4	110	76	10	39	75	74	70
MVE 41/3E-MICRO-M	MVE 41/36E-MICRO-M	F	161	25	25-40 60	92 85	6.5 6.5	4	110	76	10	39	75	74	70

Notes:

.....

.....

.....

.....

NOTE: Dimensions with coarse degree of accuracy related to UNI 22768/1

This information is provided without warranty, representation, inducement or licence of any kind. It is accurate to the best OLI knowledge or is obtained from sources believed to be accurate. OLI therefore assumes no legal responsibility. The latest and most updated information are available online.



- » Class II Div.2 Group F, G T4
- » Conform to UL 1004-1, UL 1004-3, UL60079-31, UL60079-0, CSA 60079-0, CSA 60079- 31, CSA 22.2 N°100, CSA 22.2 N°77

STANDARD

INCREASED SAFETY

EXPLOSION-PROOF

GRAIN PROCESSING

SCREEN VIBRATOR

STAINLESS STEEL

FLANGED DRIVE



# MVE STANDARD RANGE



## MVE-DC DIRECT CURRENT – 3000 rpm

II 3D Temp. Class: ● 100 °C

Wm (kgcm)	Model	rpm	Centrifugal Force (kg)	Weight (kg)	ELECTRICAL SPECIFICATIONS			
					Input Power (kW)	Nominal Current A max	Cable Gland	
1.0	MVE 50/3N-10A0-12V	3,000	50	4.4	0.08	6.60	M16	●
1.0	MVE 50/3N-10A0-24V	3,000	50	4.4	0.08	3.30	M16	●
1.1	MVE 120/3N-23A0-12V	3,000	117	5.9	0.12	9.50	M20	●
1.1	MVE 120/3N-23A0-24V	3,000	117	5.9	0.12	4.80	M20	●
4.2	MVE 200/3N-23A0-12V	3,000	200	6.3	0.16	13.30	M20	●
4.2	MVE 200/3N-23A0-24V	3,000	200	6.3	0.16	6.70	M20	●
10.4	MVE 500/3N-40A0-24V	3,000	530	15.8	0.26	11.00	M20	●
22.4	MVE 1500/3N-50A0-24V	3,000	1,616	23	0.52	21.50	M20	●

SIZE 23A0



SIZE 40A0



SIZE 50A0



To convert kg into Newton:  $N = 9.81 \cdot kg$



- » II3D Ex tc IIIC Tx IP69K
- » Equipment and protective system intended for use in potentially explosive atmospheres (Zone 22) - Directive 2014/34/UE
- » Compliance with Essential Health and Safety Requirements EN 60079-0, EN 60079-31



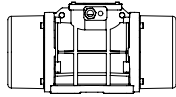

Technical drawings in the last page →

Model	Drawing	Size	DIMENSIONAL SPECIFICATIONS (mm)													
			C	M	A	B	Ø G	Holes	D	E	F	H	I	L	N	
								N°								
MVE 50/3N-10A0-12V	A	10A0	213	45	Multiple Footprint			4	130	136	12	48	94	121	85	
MVE 50/3N-10A0-24V	A	10A0	213	45	62-74	106	9									33
MVE 120/3N-23A0-12V	G	23A0	218	53	Multiple Footprint			4	164	140	25	82	116	159	110	
MVE 120/3N-23A0-24V	G	23A0	218	53	62-74	106	9									65
MVE 200/3N-23A0-12V	G	23A0	218	53	115	135	11	4	164	140	25	82	116	159	110	
MVE 200/3N-23A0-24V	G	23A0	218	53	135	115	11									
MVE 500/3N-40A0-24V	D1	40A0	330	78	105	140	13	4	170	195	15	92	174	166	160	
MVE 1500/3N-50A0-24V	D1	50A0	324	63	120	170	18	4	208	210	18	96	185	192	165	

**Notes:**

.....

.....

.....

.....

NOTE: Dimensions with coarse degree of accuracy related to UNI 22768/1

This information is provided without warranty, representation, inducement or licence of any kind. It is accurate to the best OLI knowledge or is obtained from sources believed to be accurate. OLI therefore assumes no legal responsibility. The latest and most updated information are available online.

STANDARD

INCREASED SAFETY

EXPLOSION-PROOF

GRAIN PROCESSING

SCREEN VIBRATOR

STAINLESS STEEL

FLANGED DRIVE

# MVE-Exe INCREASED SAFETY



## 2 POLES - 3000/3600 rpm

Ex II 2G: Temp. Class **T3** - ExII 2D Temp. Class: ● 100 °C ● 135 °C  
 Class II Div.2: Temp. Class **T4**  
 EX e, tE: **5**

\* Terminal Connections: **Y** High Voltage; **▲** Low Voltage

Wm (kgcm)		Model		Centrifugal Force (kg)		Weight (kg)		ELECTRICAL SPECIFICATIONS								
								Input Power (kW)		Standard Nominal Current		* Terminal Connection	Ia/In		Cable Gland	
50Hz	60Hz	50Hz	60Hz	50Hz	60Hz	50Hz	60Hz	50Hz (400V)	60Hz (460V)	50Hz	60Hz		Metric			
3.7	2.6	MVE 200/3X-20A0	MVE 200/36X-20A0	187	189	7		0.15	0.18	0.35	0.30	Y	3.	3.5	M20	●
3.7	2.6	MVE 200/3X-23A0	MVE 200/36X-23A0	187	189	7		0.15	0.18	0.35	0.30	Y	3.5	3.5	M20	●
6.4	4.5	MVE 300/3X-30A0	MVE 300/36X-30A0	321	323	10		0.25	0.28	0.52	0.45	Y	3.8	3.7	M20	●
8.0	5.7	MVE 400/3X-30A0	MVE 400/36X-30A0	407	411	10		0.27	0.33	0.58	0.60	Y	3.7	3.7	M20	●
10.3	7.4	MVE 500/3X-40A0	MVE 500/36X-40A0	530	534	16		0.50	0.58	0.96	0.97	Y	4.2	4.4	M20	●
14.9	10.6	MVE 700/3X-40A0	MVE 700/36X-40A0	758	765	17		0.59	0.61	1.25	1.24	Y	4.5	5.2	M20	●
15.7	11.1	MVE 800/3X-50A0	MVE 800/36X-50A0	794	800	20		0.70	0.84	1.45	1.50	Y	4.0	4.0	M20	●
20.3	14.0	MVE 1200/3X-50A0	MVE 1200/36X-50A0	1,005	1,013	21		0.95	1.15	1.85	1.95	Y	4.6	4.7	M20	●
26.6	18.6	MVE 1300/3X-50A0	MVE 1300/36X-50A0	1,355	1,365	22		1.30	1.38	2.44	2.25	Y	5.4	5.2	M20	●
31.3	22.2	MVE 1600/3X-60A0	MVE 1600/36X-60A0	1,601	1,608	51	50	1.54	1.60	2.94	2.61	Y	6.1	6.4	M25	●
36.8	27.6	MVE 2000/3X-60A0	MVE 2000/36X-60A0	2,027	1,997	52	50	2.10	2.10	3.75	3.42	Y	6.7	6.6	M25	●
46.0	31.9	MVE 2300/3X-60A0	MVE 2300/36X-60A0	2,302	2,306	53	51	2.40	2.45	4.44	3.45	Y	6.2	6.5	M25	●
68.1	43.9	MVE 3200/3X-75A1	MVE 3200/36X-75A1	3,252	3,176	103	101	2.76	2.90	5.30	4.61	Y	8.5	8.4	M32	●
79.4	56.0	MVE 4000/3X-75A1	MVE 4000/36X-75A1	4,033	4,052	107	104	2.90	2.90	5.30	4.61	Y	8.7	9.9	M32	●

SIZE 40A0



SIZE 50A0



SIZE 60A0



UP TO SIZE 60 (NOT INCLUDED)  
 60Hz masses = 50Hz masses adjusted at 70%



ABOVE SIZE 60 (INCLUDED)  
 Specific masses for 60Hz

To convert kg into Newton:  $N = 9.81 \cdot kg$



- » II 2D Ex tb IIIC Tx Db IP66
- » II 2G Ex eb IIC T3 Gb
- » Equipment and protective system intended for use in potentially explosive atmospheres (Zone 21 - Zone 1) - Directive 2014/34/UE
- » Compliance with Essential Health and Safety Requirements
- » IEC 60034-1, IEC EN 60079-0, IEC EN 60079-31, IEC EN 60079-7

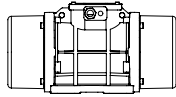

Technical drawings in the last page →

STANDARD

INCREASED SAFETY

EXPLOSION-PROOF

GRAIN PROCESSING

SCREEN VIBRATOR

STAINLESS STEEL

FLANGED DRIVE

Model		Drawing	Size	DIMENSIONAL SPECIFICATIONS (mm)												
				C		M		A	B	Ø G	Holes	D	E	F	H	I
50Hz	60Hz	50Hz	60Hz	n°												
MVE 200/3X-20A0	MVE 200/36X-20A0	B1	20A0	233	54	62-74	106	9	4	130	154	15	65	125	120	112
MVE 200/3X-23A0	MVE 200/36X-23A0	G	23A0	222	55	Multiple Footprint			4	164	140	25	82	116	159	110
						62-74	106	9								
						65	140	13								
						115	135	11								
MVE 300/3X-30A0	MVE 300/36X-30A0	C1	30A0	254	42	Multiple Footprint			4	150	173	15	79	150	166	134
						80	110	11								
						90	125	13								
						124	110	11								
MVE 400/3X-30A0	MVE 400/36X-30A0	C1	30A0	274	52	Multiple Footprint			4	150	173	15	79	150	166	134
						80	110	11								
						90	125	13								
						124	110	11								
MVE 500/3X-40A0	MVE 500/36X-40A0	D1	40A0	330	78	105	140	13	4	170	196	20	92	169	166	158
MVE 700/3X-40A0	MVE 700/36X-40A0	D1	40A0	330	78	105	140	13	4	170	196	20	92	169	166	158
MVE 800/3X-50A0	MVE 800/36X-50A0	D1	50A0	321	62	120	170	17	4	208	210	22	96	185	192	170
MVE 1200/3X-50A0	MVE 1200/36X-50A0	D1	50A0	321	62	120	170	17	4	208	210	22	96	185	192	170
MVE 1300/3X-50A0	MVE 1300/36X-50A0	D1	50A0	321	62	120	170	17	4	208	210	22	96	185	192	170
MVE 1600/3X-60A0	MVE 1600/36X-60A0	D1	60A0	402	90	140	190	17	4	230	260	26	124	240	218	222
MVE 2000/3X-60A0	MVE 2000/36X-60A0	D1	60A0	402	90	140	190	17	4	230	260	26	124	240	218	222
MVE 2300/3X-60A0	MVE 2300/36X-60A0	D1	60A0	402	90	140	190	17	4	230	260	26	124	240	218	222
MVE 3200/3X-75A1	MVE 3200/36X-75A1	D1	75A1	516	117	155	255	25	4	304	314	30	147	285	277	265
MVE 4000/3X-75A1	MVE 4000/36X-75A1	D1	75A1	516	117	155	255	25	4	304	314	30	147	285	277	265

Notes:

.....

.....

.....

.....

NOTE: Dimensions with coarse degree of accuracy related to UNI 22768/1

This information is provided without warranty, representation, inducement or licence of any kind. It is accurate to the best OLI knowledge or is obtained from sources believed to be accurate. OLI therefore assumes no legal responsibility. The latest and most updated information are available online.



- » Class I, Div.2 Group A, B, C, D T3
- » Class II Div.2 Group F, G T4
- » Conform to UL 1004-1, UL 1004-3, UL60079-31, UL60079-0, CSA 60079-0, CSA 60079-31, CSA 22.2 N°100, CSA 22.2 N°77, CSA 22.2 N°60079-7

# MVE-Exe INCREASED SAFETY



## 4 POLES - 1500/1800 rpm

Ex II 2G: Temp. Class **T3** - ExII 2D Temp. Class: ● 100 °C ● 135 °C  
 Class II Div.2: Temp. Class **T4**  
 EX e, tE: **5**

\* Terminal Connections: **Y** High Voltage; **Δ** Low Voltage

Wm (kgcm)		Model		Centrifugal Force (kg)		Weight (kg)		ELECTRICAL SPECIFICATIONS								
50Hz	60Hz	50Hz	60Hz	50Hz	60Hz	50Hz	60Hz	Input Power (kW)		Standard Nominal Current		* Terminal Connection	Ia / In		Cable Gland	
								50Hz	60Hz	50Hz (400V)	60Hz (460V)		50Hz	60Hz	Metric	
15.4	10.8	MVE 200/15X-30A0	MVE 200/18X-30A0	194	196	12		0.12	0.15	0.49	0.50	Y	2.2	2.2	M20	●
33.4	23.4	MVE 400/15X-40A0	MVE 400/18X-40A0	420	423	20		0.27	0.32	0.84	0.86	Y	2.7	2.7	M20	●
40.1	28.1	MVE 500/15X-40A0	MVE 500/18X-40A0	504	508	21		0.35	0.40	1.06	1.09	Y	3.0	2.9	M20	●
26.6	18.6	MVE 300/15X-50A0	MVE 300/18X-50A0	334	336	22		0.62	0.73	1.32	1.20	Y	3.2	3.4	M20	●
56.8	39.4	MVE 700/15X-50A0	MVE 700/18X-50A0	714	712	27		0.62	0.73	1.32	1.20	Y	3.2	3.4	M20	●
56.8	39.4	MVE 710/15X-50A0	MVE 710/18X-50A0	714	712	27		0.62	0.73	1.32	1.20	Y	3.2	3.4	M20	●
75.6	52.9	MVE 950/15X-50A0	MVE 950/18X-50A0	950	957	33		0.64	0.77	1.40	1.35	Y	4.2	4.2	M20	●
87.7	61.4	MVE 1100/15X-51A0	MVE 1100/18X-51A0	1,102	1,110	35	28.5	0.64	0.77	1.40	1.35	Y	4.0	4.0	M20	●
108.6	76.7	MVE 1400/15X-60A0	MVE 1400/18X-60A0	1,364	1,388	63	60	0.70	0.84	1.78	1.78	Y	4.2	4.2	M25	●
137.3	92.0	MVE 1700/15X-60A0	MVE 1700/18X-60A0	1,725	1,664	62	59	1.13	1.30	2.16	2.09	Y	4.9	4.7	M25	●
187.7	137.4	MVE 2400/15X-60A0	MVE 2400/18X-60A0	2,358	2,485	77	69.5	1.57	1.88	3.20	3.20	Y	5.1	5.1	M25	●
203.5	135.6	MVE 2500/15X-70A0	MVE 2500/18X-70A0	2,557	2,454	80	74	1.76	2.00	3.08	3.00	Y	6.2	6.3	M25	●
248.7	169.8	MVE 3000/15X-70A0	MVE 3000/18X-70A0	3,124	3,071	94	87	1.90	2.30	3.68	3.30	Y	6.7	6.8	M25	●
306.7	204.7	MVE 3800/15X-75A0	MVE 3800/18X-75A0	3,853	3,704	146		2.20	2.60	4.15	4.15	Y	7.0	7.0	M32	●
343.2	240.9	MVE 4300/15X-75A0	MVE 4300/18X-75A0	4,312	4,359	136	125	2.50	3.00	4.50	4.60	Y	7.2	7.4	M32	●
437.4	303.7	MVE 5500/15X-80A0	MVE 5500/18X-80A0	5,495	5,495	181	169	2.88	3.45	6.50	5.50	Y	7.3	7.2	M32	●
576.8	397.3	MVE 7200/15X-85A0	MVE 7200/18X-85A0	7,246	7,188	237	231	4.00	4.80	8.50	8.70	Δ	7.0	7.1	M32	●
718.0	498.8	MVE 9000/15X-85A0	MVE 9000/18X-85A0	9,020	9,023	252	241	7.35	8.50	13.40	12.00	Δ	7.2	7.2	M32	●
579.9	406.0	MVE 7200/15X-86A0	MVE 7200/18X-86A0	7,286	7,345	237	231	6.00	6.50	11.00	10.80	Δ	4.7	4.5	M32	●
724.8	507.0	MVE 9000/15X-86A0	MVE 9000/18X-86A0	9,106	9,172	252	241	6.00	6.50	11.00	10.80	Δ	Δ	4.5	M32	●
800.1	588.3	MVE 10000/15X-90A0	MVE 10000/18X-90A0	10,052	10,643	300	286	5.40	7.00	13.00	13.00	Δ	6.7	6.6	M32	●
835.7	581.3	MVE 10000/15X-91A0	MVE 10000/18X-91A0	10,499	10,517	300	286	7.00	8.20	13.10	13.10	Δ	7.2	7.7	M32	●

SIZE 70A0



SIZE 75A0



SIZE 80A0



**UP TO SIZE 60 (NOT INCLUDED)**  
 60Hz masses = 50Hz masses adjusted at 70%  
 Except for model MVE 1100/15E - 1100/18E



**ABOVE SIZE 60 (INCLUDED)**  
 Specific masses for 60Hz

To convert kg into Newton: **N = 9.81 · kg**



- » II 2D Ex tb IIIC Tx Db IP66
- » II 2G Ex eb IIC T3 Gb
- » Equipment and protective system intended for use in potentially explosive atmospheres (Zone 21 - Zone 1) - Directive 2014/34/UE
- » Compliance with Essential Health and Safety Requirements
- » IEC 60034-1, IEC EN 60079-0, IEC EN 60079-31, IEC EN 60079-7

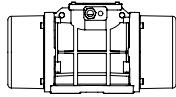

Technical drawings in the last page →

STANDARD

INCREASED SAFETY

EXPLOSION-PROOF

GRAIN PROCESSING

SCREEN VIBRATOR

STAINLESS STEEL

FLANGED DRIVE

DIMENSIONAL SPECIFICATIONS (mm)

Model		Drawing	Size	C		M		A	B	Ø G	Holes n°	D	E	F	H	I	L	N
50Hz	60Hz			50Hz	60Hz													
MVE 200/15X-30A0	MVE 200/18X-30A0	C	30A0	274	52	Multiple Footprint 80 110 11 90 125 13 124 110 11 135 115 11			4	150	173	15	79	150	166	134		
MVE 400/15X-40A0	MVE 400/18X-40A0	D1	40A0	330	78	105	140	13	4	170	196	20	92	174	166	160		
MVE 500/15X-40A0	MVE 500/18X-40A0	D1	40A0	330	78	105	140	13	4	170	196	20	92	174	166	160		
MVE 300/15X-50A0	MVE 300/18X-50A0	D1	50A0	321	62	120	170	17	4	208	210	22	96	185	192	170		
MVE 700/15X-50A0	MVE 700/18X-50A0	D1	50A0	391	97	120	170	17	4	208	210	22	96	185	192	170		
MVE 710/15X-50A0	MVE 710/18X-50A0	D1	50A0	391	97	120	170	17	4	208	210	22	96	185	192	170		
MVE 950/15X-50A0	MVE 950/18X-50A0	D1	50A0	455	129	120	170	17	4	208	210	22	96	185	192	170		
MVE 1100/15X-51A0	MVE 1100/18X-51A0	D1	51A0	414	106	120	170	17	4	208	220	25	105	202	192	187		
MVE 1400/15X-60A0	MVE 1400/18X-60A0	D1	60A0	446	112	140	190	17	4	230	260	26	124	240	218	222		
MVE 1700/15X-60A0	MVE 1700/18X-60A0	D1	60A0	446	112	140	190	17	4	230	260	26	124	240	218	222		
MVE 2400/15X-60A0	MVE 2400/18X-60A0	D1	60A0	490	446	134	112	140	190	17	4	230	260	26	124	240	218	222
MVE 2500/15X-70A0	MVE 2500/18X-70A0	D1	70A0	501	123	155	225	22	4	275	290	30	140	256	250	236		
MVE 3000/15X-70A0	MVE 3000/18X-70A0	D1	70A0	535	501	140	123	155	225	22	4	275	290	30	140	256	250	236
MVE 3800/15X-75A0	MVE 3800/18X-75A0	D1	75A0	564	536	151	117	155	255	23.5	4	304	314	30	147	285	277	265
MVE 4300/15X-75A0	MVE 4300/18X-75A0	D1	75A0	584	564	151	141	155	255	23.5	4	304	314	30	147	285	277	265
MVE 5500/15X-80A0	MVE 5500/18X-80A0	E1	80A0	603	143	180	280	26	4	332	360	37	167	345	304	310		
MVE 7200/15X-85A0	MVE 7200/18X-85A0	D1	85A0	624	130	200	320	28	4	385	402	40	203	394	360	378		
MVE 9000/15X-85A0	MVE 9000/18X-85A0	D1	85A0	624	130	200	320	28	4	385	402	40	203	394	360	378		
MVE 7200/15X-86A0	MVE 7200/18X-86A0	D1	86A0	624	130	200	320	28	4	385	402	40	203	394	360	378		
MVE 9000/15X-86A0	MVE 9000/18X-86A0	D1	86A0	624	130	200	320	28	4	385	402	40	203	394	360	378		
MVE 10000/15X-90A0	MVE 10000/18X-90A0	E1	90A0	728	170	125	380	39	6	452	415	40	205	394	380	378		
MVE 10000/15X-91A0	MVE 10000/18X-91A0	E1	91A0	728	170	125	380	39	6	452	415	40	205	394	380	378		

Notes:

NOTE: Dimensions with coarse degree of accuracy related to UNI 22768/1

This information is provided without warranty, representation, inducement or licence of any kind. It is accurate to the best OLI knowledge or is obtained from sources believed to be accurate. OLI therefore assumes no legal responsibility. The latest and most updated information are available online.



- » Class I, Div.2 Group A, B, C, D T3
- » Class II Div.2 Group F, G T4
- » Conform to UL 1004-1, UL 1004-3, UL60079-31, UL60079-0, CSA 60079-0, CSA 60079-31, CSA 22.2 N°100, CSA 22.2 N°77, CSA 22.2 N°60079-7

# MVE-Exe INCREASED SAFETY



## 6 POLES - 1000/1200 rpm

Ex II 2G: Temp. Class **T3** - ExII 2D Temp. Class: ● 100 °C ● 135 °C  
 Class II Div.2: Temp. Class **T4**  
 EX e, tE: **5**

\* Terminal Connections: **Y** High Voltage; **▲** Low Voltage

Wm (kgcm)		Model		Centrifugal Force (kg)		Weight (kg)		ELECTRICAL SPECIFICATIONS								
								Input Power (kW)		Standard Nominal Current		* Terminal Connection	Ia / In		Cable Gland	
50Hz	60Hz	50Hz	60Hz	50Hz	60Hz	50Hz	60Hz	50Hz (400V)	60Hz (460V)	50Hz	60Hz		Metric			
9.5	6.6	MVE 50/1X-30A0	MVE 50/12X-30A0	53	53	10		0.12	0.14	0.30	0.40	Y	2.2	2.2	M20	●
18.8	13.2	MVE 100/1X-30A0	MVE 100/12X-30A0	105	106	11		0.12	0.14	0.30	0.40	Y	2.2	2.2	M20	●
33.5	23.4	MVE 200/1X-40A0	MVE 200/12X-40A0	187	188	19		0.15	0.18	0.65	0.63	Y	2.2	2.2	M20	●
56.9	39.9	MVE 300/1X-50A0	MVE 300/12X-50A0	318	320	26		0.25	0.30	0.67	0.64	Y	2.7	2.7	M20	●
91.9	64.3	MVE 500/1X-50A0	MVE 500/12X-50A0	513	517	34		0.55	0.40	1.22	1.15	Y	3.0	2.9	M20	●
91.9	91.9	MVE 510/1X-51A0	MVE 510/12X-51A0	513	739	34		0.55	0.40	1.20	1.15	Y	3.0	2.9	M20	●
137.4	108.6	MVE 800/1X-60A0	MVE 800/12X-60A0	767	873	60 58		0.75	0.80	1.42	1.32	Y	3.4	3.3	M25	●
187.7	137.3	MVE 1100/1X-60A0	MVE 1100/12X-60A0	1,048	1,104	78 72		0.75	0.80	1.42	1.32	Y	3.4	3.3	M25	●
284.8	196.5	MVE 1500/1X-60A0	MVE 1500/12X-60A0	1,590	1,580	84 73		0.90	1.08	1.80	2.00	Y	3.5	3.5	M25	●
299.6	203.5	MVE 1600/1X-70A0	MVE 1600/12X-70A0	1,673	1,636	90 79		0.90	1.08	2.40	2.30	Y	3.9	3.8	M25	●
373.1	248.7	MVE 2100/1X-70A0	MVE 2100/12X-70A0	2,083	2,000	105 91		1.50	1.80	3.00	3.20	Y	4.5	4.6	M25	●
467.4	306.7	MVE 2600/1X-75A0	MVE 2600/12X-75A0	2,610	2,466	146.5 126.5		1.96	2.10	4.10	4.00	Y	5.0	5.0	M32	●
540.3	379.7	MVE 3000/1X-75A0	MVE 3000/12X-75A0	3,017	3,053	155 138		2.20	2.40	4.50	4.30	Y	5.2	5.2	M32	●
702.5	465.6	MVE 3700/1X-75A0	MVE 3700/12X-75A0	3,797	3,744	159 142		2.20	2.40	4.50	4.30	Y	5.2	5.2	M32	●
680.4	437.4	MVE 3800/1X-80A0	MVE 3800/12X-80A0	3,799	3,517	216 195		2.50	3.00	5.50	5.30	Y	6.1	6.2	M32	●
838.3	584.2	MVE 4700/1X-80A0	MVE 4700/12X-80A0	4,681	4,697	220 201		3.20	3.90	6.50	6.95	Y	5.7	5.9	M32	●
929.9	654.6	MVE 5200/1X-85A0	MVE 5200/12X-85A0	5,192	5,263	264 248		3.80	4.00	6.92	6.36	Y	5.7	5.7	M32	●
1,165.2	824.0	MVE 6500/1X-85A0	MVE 6500/12X-85A0	6,506	6,625	288 265		4.30	5.00	7.76	7.81	Y	6.4	6.2	M32	●
1,436.0	929.8	MVE 8000/1X-85A0	MVE 8000/12X-85A0	8,018	7,476	309 274		5.50	6.60	12.60	11.60	▲	6.2	6.4	M32	●
1,600.4	1,165.2	MVE 9000/1X-85A0	MVE 9000/12X-85A0	8,936	9,369	322 291		6.20	7.45	13.20	12.60	▲	6.5	6.4	M32	●
1,434.0	929.8	MVE 8000/1X-86A0	MVE 8000/12X-86A0	8,007	7,476	309 274		4.60	5.50	9.00	10.00	▲	6.0	6.2	M32	●
1,598.0	1,165.2	MVE 9000/1X-86A0	MVE 9000/12X-86A0	8,923	9,369	322 291		4.60	5.50	9.00	10.00	▲	6.0	6.2	M32	●
1,788.4	1,240.0	MVE 10000/1X-90A0	MVE 10000/12X-90A0	9,986	9,970	374 348		6.10	6.40	14.00	12.70	▲	6.6	6.6	M32	●
2,329.8	1,647.4	MVE 13000/1X-90A0	MVE 13000/12X-90A0	13,009	13,246	411 364		7.50	8.30	16.40	16.00	▲	6.4	6.5	M32	●
1,802.9	1,240.0	MVE 10000/1X-91A0	MVE 10000/12X-91A0	10,067	9,970	373 348		6.40	7.70	13.00	14.50	▲	6.0	6.0	M32	●
2,056.9	1,433.0	MVE 11400/1X-91A0	MVE 11400/12X-91A0	11,485	11,522	404 361		6.40	7.70	13.00	7.50	▲	6.0	6.0	M32	●



UP TO SIZE 60 (NOT INCLUDED)  
60Hz masses = 50Hz masses adjusted at 70%



ABOVE SIZE 60 (INCLUDED)  
Specific masses for 60Hz

To convert kg into Newton: **N = 9.81 · kg**



- » II 2D Ex tb IIC Tx Db IP66
- » II 2G Ex eb IIC T3 Gb
- » Equipment and protective system intended for use in potentially explosive atmospheres (Zone 21 - Zone 1) - Directive 2014/34/UE
- » Compliance with Essential Health and Safety Requirements
- » IEC 60034-1, IEC EN 60079-0, IEC EN 60079-31, IEC EN 60079-7

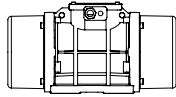

Technical drawings in the last page →

STANDARD

INCREASED SAFETY

EXPLOSION-PROOF

GRAIN PROCESSING

SCREEN VIBRATOR

STAINLESS STEEL

FLANGED DRIVE

Model		Drawing	Size	DIMENSIONAL SPECIFICATIONS (mm)														
				C		M		A	B	Ø G	Holes	D	E	F	H	I	L	N
50Hz	60Hz			50Hz	60Hz	50Hz	60Hz				n°							
MVE 50/1X-30A0	MVE 50/12X-30A0	C	30A0	274	52	Multiple Footprint			4	150	173	15	79	150	166	134		
						80	110	11										
						90	125	13										
						124	110	11										
MVE 100/1X-30A0	MVE 100/12X-30A0	C	30A0	304	67	Multiple Footprint			4	150	173	15	79	150	166	134		
						80	110	11										
						90	125	13										
						124	110	11										
MVE 200/1X-40A0	MVE 200/12X-40A0	D1	40A0	330	78	105	140	13	4	170	196	20	92	174	166	160		
MVE 300/1X-50A0	MVE 300/12X-50A0	D1	50A0	391	97	120	170	17	4	208	210	22	96	185	192	170		
MVE 500/1X-50A0	MVE 500/12X-50A0	D1	50A0	455	129	120	170	17	4	208	210	22	96	185	192	170		
MVE 510/1X-51A0	MVE 510/12X-51A0	D1	51A0	455	129	120	170	17	4	208	210	22	96	185	192	170		
MVE 800/1X-60A0	MVE 800/12X-60A0	D1	60A0	446	112	140	190	17	4	230	260	26	124	240	218	222		
MVE 1100/1X-60A0	MVE 1100/12X-60A0	D1	60A0	490	446	134	112	140	190	17	4	230	260	26	124	240	218	222
MVE 1500/1X-60A0	MVE 1500/12X-60A0	D1	60A0	566	490	172	134	140	190	17	4	230	260	26	124	240	218	222
MVE 1600/1X-70A0	MVE 1600/12X-70A0	D1	70A0	563	501	154	123	155	225	22	4	275	290	30	140	256	250	236
MVE 2100/1X-70A0	MVE 2100/12X-70A0	D1	70A0	623	563	184	154	155	225	22	4	275	290	30	140	256	250	236
MVE 2600/1X-75A0	MVE 2600/12X-75A0	D1	75A0	692	584	205	151	155	255	23.5	4	304	314	30	147	285	277	265
MVE 3000/1X-75A0	MVE 3000/12X-75A0	D1	75A0	692	205	155	255	23.5	4	304	314	30	147	285	277	265		
MVE 3700/1X-75A0	MVE 3700/12X-75A0	D1	75A0	734	692	226	205	155	255	23.5	4	304	314	30	147	285	277	265
MVE 3800/1X-80A0	MVE 3800/12X-80A0	D1	80A0	683	603	183	143	180	280	26	4	332	354	32	170	330	312	311
MVE 4700/1X-80A0	MVE 4700/12X-80A0	D1	80A0	733	683	208	183	180	280	26	4	332	354	32	170	330	312	311
MVE 5200/1X-85A0	MVE 5200/12X-85A0	D1	85A0	704	624	170	130	200	320	28	4	385	402	40	20	394	360	378
MVE 6500/1X-85A0	MVE 6500/12X-85A0	D1	85A0	704	170	200	320	28	4	385	402	40	20	394	360	378		
MVE 8000/1X-85A0	MVE 8000/12X-85A0	D1	85A0	774	704	205	170	200	320	28	4	385	402	40	203	394	360	378
MVE 9000/1X-85A0	MVE 9000/12X-85A0	D1	85A0	774	704	205	170	200	320	28	4	385	402	40	203	394	360	378
MVE 8000/1X-86A0	MVE 8000/12X-86A0	D1	86A0	774	205	200	320	28	4	385	402	40	203	394	360	378		
MVE 9000/1X-86A0	MVE 9000/12X-86A0	D1	86A0	774	205	200	320	28	4	385	402	40	203	394	360	378		
MVE 10000/1X-90A0	MVE 10000/12X-90A0	E1	90A0	908	798	260	205	125	380	39	6	452	415	40	205	394	380	378
MVE 13000/1X-90A0	MVE 13000/12X-90A0	E1	90A0	948	798	280	205	125	380	39	6	452	415	40	205	394	380	378
MVE 10000/1X-91A0	MVE 10000/12X-91A0	E1	91A0	908	260	125	380	39	6	452	415	40	205	394	380	378		
MVE 11400/1X-91A0	MVE 11400/12X-91A0	E1	91A0	908	260	125	380	39	6	452	415	40	205	394	380	378		

NOTE: Dimensions with coarse degree of accuracy related to UNI 22768/1

This information is provided without warranty, representation, inducement or licence of any kind. It is accurate to the best OLI knowledge or is obtained from sources believed to be accurate. OLI therefore assumes no legal responsibility. The latest and most updated information are available online.



- » Class I, Div.2 Group A, B, C, D T3
- » Class II Div.2 Group F, G T4
- » Conform to UL 1004-1, UL 1004-3, UL60079-31, UL60079-0, CSA 60079-0, CSA 60079-31, CSA 22.2 N°100, CSA 22.2 N°77, CSA 22.2 N°60079-7

# MVE-Exe INCREASED SAFETY



## 8 POLES - 750/900 rpm

Ex II 2G: Temp. Class **T3** - ExII 2D Temp. Class: ● 100 °C ● 135 °C  
 Class II Div.2: Temp. Class **T4**  
 EX e, tE: **5**

\* Terminal Connections: **Y** High Voltage; **Δ** Low Voltage

Wm (kgcm)		Model				Centrifugal Force (kg)		Weight (kg)		ELECTRICAL SPECIFICATIONS							
										Input Power (kW)		Standard Nominal Current		* Terminal Connection	Ia / In		Cable Gland
										50Hz	60Hz	50Hz (400V)	60Hz (460V)		50Hz	60Hz	
33.4	60Hz	MVE 150/075X-40A0	MVE 150/090X-40A0	105	151	21	0.23	0.25	1.14	1.14	Y	1.7	1.7	M20	●		
56.9	60Hz	MVE 250/075X-50A0	MVE 250/090X-50A0	179	257	29	0.25	0.30	0.90	0.89	Y	1.9	1.9	M20	●		
84.0	60Hz	MVE 400/075X-51A0	MVE 400/090X-51A0	264	380	34	0.25	0.30	0.90	0.89	Y	2.1	2.1	M20	●		
137.3	60Hz	MVE 650/075X-60A0	MVE 650/090X-60A0	431	621	63	0.37	0.45	1.20	1.20	Y	2.4	2.4	M25	●		
187.7	60Hz	MVE 900/075X-60A0	MVE 900/090X-60A0	589	849	70	0.55	0.54	1.23	1.29	Y	2.7	2.7	M25	●		
299.6	60Hz	MVE 1300/075X-70A0	MVE 1300/090X-70A0	941	1,355	90	0.75	0.90	2.20	2.20	Y	3.2	3.2	M25	●		
467.4	60Hz	MVE 2100/075X-75A0	MVE 2100/090X-75A0	1,468	2,114	150	1.00	1.20	2.81	2.89	Y	4.4	4.3	M32	●		
680.3	60Hz	MVE 3100/075X-80A0	MVE 3100/090X-80A0	2,137	3,077	201	2.00	2.30	4.50	4.40	Y	4.2	4.2	M32	●		
838.4	60Hz	MVE 3800/075X-80A0	MVE 3800/090X-80A0	2,633	3,792	219	2.50	3.00	6.00	6.00	Y	4.1	4.2	M32	●		
929.7	60Hz	MVE 4200/075X-85A0	MVE 4200/090X-85A0	2,920	4,205	268	2.90	3.40	6.50	6.50	Y	4.0	3.9	M32	●		
1,165.2	60Hz	MVE 5300/075X-85A0	MVE 5300/090X-85A0	3,660	5,270	289	3.70	4.30	8.00	8.20	Y	4.0	4.4	M32	●		
1,435.9	60Hz	MVE 6500/075X-85A0	MVE 6500/090X-85A0	4,510	6,494	308	3.80	4.20	8.78	8.30	Y	3.8	4.2	M32	●		
2,200.4	60Hz	MVE 10000/075X-90A0	MVE 10000/090X-90A0	6,911	9,952	422	6.80	7.50	13.50	12.50	Δ	3.7	4.4	M32	●		
2,311.0	60Hz	MVE 10000/075X-91A0	MVE 10000/090X-91A0	7,258	10,452	422	6.00	7.00	14.40	14.00	Δ	4.7	4.7	M32	●		

SIZE 80A0



SIZE 86A0



SIZE 91A0



60Hz masses = 50Hz masses adjusted at 100%

To convert kg into Newton: **N = 9.81 · kg**



- » II 2D Ex tb IIIC Tx Db IP66
- » II 2G Ex eb IIC T3 Gb
- » Equipment and protective system intended for use in potentially explosive atmospheres (Zone 21 - Zone 1) - Directive 2014/34/UE
- » Compliance with Essential Health and Safety Requirements
- » IEC 60034-1, IEC EN 60079-0, IEC EN 60079-31, IEC EN 60079-7



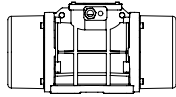

Technical drawings in the last page →

Model		Drawing	Size	DIMENSIONAL SPECIFICATIONS (mm)												
				C	M	A	B	Ø G	Holes n°	D	E	F	H	I	L	N
50Hz	60Hz			50Hz-60Hz	50Hz-60Hz											
MVE 150/075X-40A0	MVE 150/090X-40A0	D1	40A0	330	78	105	140	13	4	170	196	20	92	174	166	160
MVE 250/075X-50A0	MVE 250/090X-50A0	D1	50A0	391	97	120	170	17	4	208	210	22	96	185	192	170
MVE 400/075X-51A0	MVE 400/090X-51A0	D1	51A0	455	129	120	170	17	4	208	210	22	96	185	192	170
MVE 650/075X-60A0	MVE 650/090X-60A0	D1	60A0	446	112	140	190	17	4	230	260	26	124	240	218	222
MVE 900/075X-60A0	MVE 900/090X-60A0	D1	60A0	490	134	140	190	17	4	230	260	26	124	240	218	222
MVE 1300/075X-70A0	MVE 1300/090X-70A0	D1	70A0	563	154	155	225	22	4	275	290	30	140	256	250	236
MVE 2100/075X-75A0	MVE 2100/090X-75A0	D1	75A0	692	205	155	255	23.5	4	304	314	30	147	285	277	265
MVE 3100/075X-80A0	MVE 3100/090X-80A0	D1	80A0	683	183	180	280	26	4	332	354	32	170	330	312	311
MVE 3800/075X-80A0	MVE 3800/090X-80A0	D1	80A0	733	208	180	280	26	4	332	354	32	170	330	312	311
MVE 4200/075X-85A0	MVE 4200/090X-85A0	D1	85A0	704	170	200	320	28	4	385	402	40	203	394	360	378
MVE 5300/075X-85A0	MVE 5300/090X-85A0	D1	85A0	704	170	200	320	28	4	385	402	40	203	394	360	378
MVE 6500/075X-85A0	MVE 6500/090X-85A0	D1	85A0	774	205	200	320	28	4	385	402	40	203	394	360	378
MVE 10000/075X-90A0	MVE 10000/090X-90A0	E1	90A0	948	280	125	380	39	6	452	415	40	205	394	380	378
MVE 10000/075X-91A0	MVE 10000/090X-91A0	E1	91A0	948	280	125	380	39	6	452	415	40	205	394	380	378

Notes:

.....

.....

.....

.....

NOTE: Dimensions with coarse degree of accuracy related to UNI 22768/1

This information is provided without warranty, representation, inducement or licence of any kind. It is accurate to the best OLI knowledge or is obtained from sources believed to be accurate. OLI therefore assumes no legal responsibility. The latest and most updated information are available online.



- » Class I, Div.2 Group A, B, C, D T3
- » Class II Div.2 Group F, G T4
- » Conform to UL 1004-1, UL 1004-3, UL60079-31, UL60079-0, CSA 60079-0, CSA 60079-31, CSA 22.2 N°100, CSA 22.2 N°77, CSA 22.2 N°60079-7

STANDARD

INCREASED SAFETY

EXPLOSION-PROOF

GRAIN PROCESSING

SCREEN VIBRATOR

STAINLESS STEEL

FLANGED DRIVE

# MVE-Exd EXPLOSION-PROOF



Ex II 2G: Temp. Class **T4**  
 Class I Div.1: Temp. Class **T4**  
 Ex II 2D Temp. Class: ● **135 °C**

\* Terminal Connections: **Y** High Voltage; **▲** Low Voltage

## 2 POLES - 3000/3600 rpm

Wm (kgcm)		Model		Centrifugal Force (kg)		Weight (kg)		ELECTRICAL SPECIFICATIONS							
50Hz	60Hz	50Hz	60Hz	50Hz	60Hz	50Hz	60Hz	Input Power (kW)		Standard Nominal Current		* Terminal Connection	Ia / In		Cable Gland
								50Hz	60Hz	50Hz (400V)	60Hz (460V)		50Hz	60Hz	Metric
15.7	11.1	MVE 800/3D-50A0	MVE 800/36D-50A0	794	800	40		0.75	0.90	1.45	1.50	Y	3.8	3.8	3/4" NPT 110 °C ●
26.6	18.6	MVE 1300/3D-50A0	MVE 1300/36D-50A0	1,355	1,365	41		1.10	1.10	2.00	2.75	Y	5.2	5.0	3/4" NPT 110 °C ●
31.3	22.2	MVE 1600/3D-60A0	MVE 1600/36D-60A0	1,601	1,608	63	62	1.57	1.60	2.94	2.61	Y	5.9	6.2	3/4" NPT 110 °C ●
36.8	27.6	MVE 2000/3D-60A0	MVE 2000/36D-60A0	2,027	1,997	64	63	1.25	1.40	3.20	2.80	Y	6.5	6.4	3/4" NPT 110 °C ●
46.0	31.9	MVE 2300/3D-60A1	MVE 2300/36D-60A1	2,302	2,306	65	63	1.25	1.40	3.20	2.80	Y	6.0	6.3	3/4" NPT 110 °C ●
68.1	43.9	MVE 3200/3D-75A0	MVE 3200/36D-75A0	3,252	3,176	105	103	3.00	3.00	5.20	4.60	Y	8.3	8.2	3/4" NPT 110 °C ●
79.4	56.0	MVE 4000/3D-75A0	MVE 4000/36D-75A0	4,033	4,052	108	104	3.00	3.00	5.20	4.60	Y	8.5	9.7	3/4" NPT 110 °C ●

## 4 POLES - 1500/1800 rpm

Wm (kgcm)		Model		Centrifugal Force (kg)		Weight (kg)		ELECTRICAL SPECIFICATIONS							
50Hz	60Hz	50Hz	60Hz	50Hz	60Hz	50Hz	60Hz	Input Power (kW)		Standard Nominal Current		* Terminal Connection	Ia / In		Cable Gland
								50Hz	60Hz	50Hz (400V)	60Hz (460V)		50Hz	60Hz	Metric
56.8	39.4	MVE 700/15D-50A0	MVE 700/18D-50A0	714	712	45		0.55	0.66	1.00	1.00	Y	3.0	3.2	3/4" NPT 110 °C ●
88.7	56.8	MVE 1100/15D-50A0	MVE 1100/18D-50A0	1,114	1,028	52	45	0.60	0.68	1.27	1.50	Y	3.8	3.8	3/4" NPT 110 °C ●
108.6	76.7	MVE 1400/15D-60A0	MVE 1400/18D-60A0	1,364	1,388	73	70	0.75	1.00	1.67	1.80	Y	4.0	4.0	3/4" NPT 110 °C ●
137.3	92.0	MVE 1700/15D-60A1	MVE 1700/18D-60A1	1,725	1,664	76	61	1.00	1.20	1.95	2.00	Y	4.7	4.5	3/4" NPT 110 °C ●
187.7	137.4	MVE 2400/15D-60A1	MVE 2400/18D-60A1	2,358	2,485	78	72	1.25	1.40	2.80	2.70	Y	4.9	4.9	3/4" NPT 110 °C ●
203.5	135.6	MVE 2500/15D-70A0	MVE 2500/18D-70A0	2,557	2,454	99	93	1.50	1.60	2.70	2.60	Y	6.0	6.1	3/4" NPT 110 °C ●
248.7	169.8	MVE 3000/15D-70A0	MVE 3000/18D-70A0	3,124	3,071	105	97	1.65	1.90	2.80	2.70	Y	6.5	6.6	3/4" NPT 110 °C ●
306.7	204.7	MVE 3800/15D-75A0	MVE 3800/18D-75A0	3,853	3,704	136	125	2.30	2.25	4.10	3.96	Y	6.8	6.8	3/4" NPT 110 °C ●
343.2	240.9	MVE 4300/15D-75A0	MVE 4300/18D-75A0	4,312	4,359	140	130	2.40	2.60	4.30	4.10	Y	7.0	7.2	3/4" NPT 110 °C ●
437.4	303.7	MVE 5500/15D-80A0	MVE 5500/18D-80A0	5,495	5,495	193	183	3.10	3.10	5.70	5.30	Y	7.1	7.0	3/4" NPT 110 °C ●

SIZE 50A0



**UP TO SIZE 50 (INCLUDED)**  
 60Hz masses = 50Hz masses adjusted at 70%  
 Except for model MVE 1100/15D - 1100/18D



**ABOVE SIZE 50 (NOT INCLUDED)**  
 Specific masses for 60Hz

To convert kg into Newton: **N = 9.81 · kg**



- » II 2G Ex db IIB T4 Gb,
- » II 2D Ex tb IIIC T135°C Db
- » Ex db IIB T4 Gb
- » Ex tb IIIC T135°C Db
- » Ambient temperature from -20°C to +60°C

- » Compliance with Essential Health and Safety Requirements
- » IEC EN 60079-0, IEC EN 60079-31, IEC EN 60079-1

X

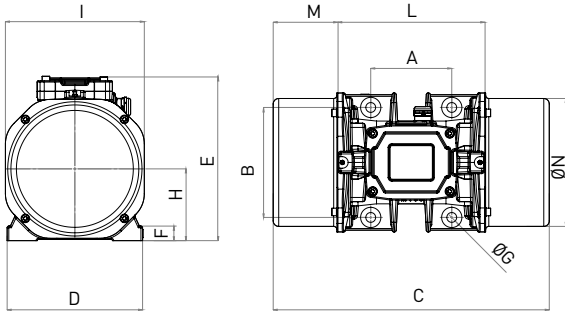

Y

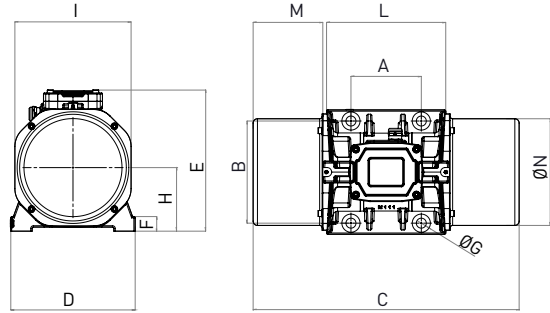

DIMENSIONAL SPECIFICATIONS (mm)

Model		Drawing	Size	DIMENSIONAL SPECIFICATIONS (mm)														
50Hz	60Hz			C		M		A	B	ØG	Holes n°	D	E	F	H	I	L	N
				50Hz	60Hz	50Hz	60Hz											
MVE 800/3D-50A0	MVE 800/36D-50A0	X	50A0	332		63		120	170	17	4	209	251	27	103	185	205	165
MVE 1300/3D-50A0	MVE 1300/36D-50A0	X	50A0	332		63		120	170	17	4	209	251	27	103	185	205	165
MVE 1600/3D-60A0	MVE 1600/36D-60A0	X	60A0	477		111		140	190	17	4	234	283	25	124	240	254	221
MVE 2000/3D-60A0	MVE 2000/36D-60A0	X	60A0	477		111		140	190	17	4	234	283	25	124	240	254	221
MVE 2300/3D-60A1	MVE 2300/36D-60A1	X	60A1	477		111		140	190	22	4	234	283	25	124	240	254	221
MVE 3200/3D-75A0	MVE 3200/36D-75A0	Y	75A0	540		118		155	255	23.5	4	302	330	30	150	280	304	265
MVE 4000/3D-75A0	MVE 4000/36D-75A0	Y	75A0	554		125		155	255	23.5	4	302	330	30	150	280	304	265

DIMENSIONAL SPECIFICATIONS (mm)

Model		Drawing	Size	DIMENSIONAL SPECIFICATIONS (mm)														
50Hz	60Hz			C		M		A	B	ØG	Holes n°	D	E	F	H	I	L	N
				50Hz	60Hz	50Hz	60Hz											
MVE 700/15D-50A0	MVE 700/18D-50A0	X	50A0	396		95		120	170	17	4	209	251	27	103	185	205	165
MVE 1100/15D-50A0	MVE 1100/18D-50A0	X	50A0	466	396	130	95	120	170	17	4	209	251	27	103	185	205	165
MVE 1400/15D-60A0	MVE 1400/18D-60A0	X	60A0	477		111		140	190	17	4	234	283	25	124	240	254	221
MVE 1700/15D-60A1	MVE 1700/18D-60A1	X	60A1	477		111		140	190	22	4	234	283	25	124	240	254	221
MVE 2400/15D-60A1	MVE 2400/18D-60A1	X	60A1	521		133		140	190	22	4	234	283	25	124	240	254	221
MVE 2500/15D-70A0	MVE 2500/18D-70A0	Y	70A0	525		123		155	225	22	4	274	311	32	140	256	279	235
MVE 3000/15D-70A0	MVE 3000/18D-70A0	Y	70A0	586		153		155	225	22	4	274	311	32	140	256	279	235
MVE 3800/15D-75A0	MVE 3800/18D-75A0	Y	75A0	596		146		155	255	23.5	4	302	330	30	150	280	304	265
MVE 4300/15D-75A0	MVE 4300/18D-75A0	Y	75A0	616		156		155	255	23.5	4	302	330	30	150	280	304	265
MVE 5500/15D-80A0	MVE 5500/18D-80A0	Y	80A0	612		127		180	280	26	4	330	379	33	176	330	358	310

Notes:

.....

.....

.....

.....

NOTE: Dimensions with coarse degree of accuracy related to UNI 22768/1

This information is provided without warranty, representation, inducement or licence of any kind. It is accurate to the best OLI knowledge or is obtained from sources believed to be accurate. OLI therefore assumes no legal responsibility. The latest and most updated information are available online.



- » Class I, Div.1 Group C, D T4 IP66
- » Conform to UL 1004-1, UL 1004-3, UL 1203, UL 674, CSA C22.2 No.145, CSA C22.2 No.30-M1986.

STANDARD

INCREASED SAFETY

EXPLOSION-PROOF

GRAIN PROCESSING

SCREEN VIBRATOR

STAINLESS STEEL

FLANGED DRIVE



# MVE-Exd EXPLOSION-PROOF



Ex II 2G: Temp. Class **T4**  
 Class I Div.1: Temp. Class **T4**  
 Ex II 2D Temp. Class: ● **135 °C**

\* Terminal Connections: **Y** High Voltage; **▲** Low Voltage

## 6 POLES - 1000/1200 rpm

Wm (kgcm)		Model		Centrifugal Force (kg)		Weight (kg)		ELECTRICAL SPECIFICATIONS							
								Input Power (kW)		Standard Nominal Current		* Terminal Connection	Ia/In		Cable Gland
50Hz	60Hz	50Hz	60Hz	50Hz	60Hz	50Hz	60Hz	50Hz	60Hz	50Hz (400V)	60Hz (460V)		* Terminal Connection	50Hz	60Hz
91.9		MVE 500/1D-50A0	MVE 500/12D-50A0	513	739	54		0.30	0.32	1.10	1.05	Y		2.8	2.7
137.4	108.6	MVE 800/1D-60A0	MVE 800/12D-60A0	767	873	73	71	0.57	0.68	1.14	1.21	Y	3.2	3.1	3/4" NPT 110 °C
187.7	137.3	MVE 1100/1D-60A1	MVE 1100/12D-60A1	1,048	1,104	80	74	0.56	0.58	1.40	1.30	Y	3.2	3.1	3/4" NPT 110 °C
284.8	196.5	MVE 1500/1D-60A0	MVE 1500/12D-60A0	1,590	1,580	94	83	0.80	0.90	1.60	1.70	Y	3.3	3.3	3/4" NPT 110 °C
299.6	203.5	MVE 1600/1D-70A0	MVE 1600/12D-70A0	1,673	1,636	109	99	1.00	1.13	2.50	2.72	Y	3.7	3.6	3/4" NPT 110 °C
373.1	248.7	MVE 2100/1D-70A0	MVE 2100/12D-70A0	2,083	2,000	121	107	1.20	1.35	2.80	3.00	Y	4.3	4.4	3/4" NPT 110 °C
467.4	306.7	MVE 2600/1D-75A0	MVE 2600/12D-75A0	2,610	2,466	153	136	1.50	1.60	3.50	3.30	Y	4.8	4.8	3/4" NPT 110 °C
540.3	379.7	MVE 3000/1D-75A0	MVE 3000/12D-75A0	3,017	3,053	161	135	1.75	1.90	4.30	4.00	Y	5.0	5.0	3/4" NPT 110 °C
680.4	437.4	MVE 3800/1D-80A0	MVE 3800/12D-80A0	3,799	3,517	215	196	2.10	2.30	5.00	4.80	Y	5.9	6.0	3/4" NPT 110 °C
838.3	584.2	MVE 4700/1D-80A0	MVE 4700/12D-80A0	4,681	4,697	231	212	2.50	2.80	6.20	6.00	Y	5.5	5.7	3/4" NPT 110 °C

## 8 POLES - 750/900 rpm

Wm (kgcm)		Model		Centrifugal Force (kg)		Weight (kg)		ELECTRICAL SPECIFICATIONS							
								Input Power (kW)		Standard Nominal Current		* Terminal Connection	Ia/In		Cable Gland
50Hz	60Hz	50Hz	60Hz	50Hz	60Hz	50Hz-60Hz	50Hz	60Hz	50Hz (400V)	60Hz (460V)	* Terminal Connection		50Hz	60Hz	Metric
56.9		MVE 250/075D-50A0	MVE 250/090D-50A0	179	257	47		0.35	0.38	1.15		1.15	Y	1.7	1.7
84.0		MVE 400/075D-50A0	MVE 400/090D-50A0	264	380	54		0.35	0.38	1.15	1.15	Y	1.9	1.9	3/4" NPT 110 °C
137.3		MVE 650/075D-60A0	MVE 650/090D-60A0	431	621	73		0.43	0.50	1.12	1.10	Y	2.2	2.2	3/4" NPT 110 °C
187.7		MVE 900/075D-60A1	MVE 900/090D-60A1	589	849	82		0.55	0.60	1.40	1.20	Y	2.5	2.5	3/4" NPT 110 °C
299.6		MVE 1300/075D-70A0	MVE 1300/090D-70A0	941	1,355	109		0.80	0.80	2.20	2.10	Y	3.0	3.0	3/4" NPT 110 °C
467.4		MVE 2100/075D-75A0	MVE 2100/090D-75A0	1,468	2,114	153		1.25	1.30	3.20	2.80	Y	4.2	4.1	3/4" NPT 110 °C
680.3		MVE 3100/075D-80A0	MVE 3100/090D-80A0	2,137	3,077	214		1.50	1.80	3.80	3.80	Y	4.0	4.0	3/4" NPT 110 °C
838.4		MVE 3800/075D-80A0	MVE 3800/090D-80A0	2,633	3,792	230		2.50	3.20	5.50	5.70	Y	3.9	4.0	3/4" NPT 110 °C

SIZE 60A0



To convert kg into Newton: **N = 9.81 · kg**



- » II 2G Ex db IIB T4 Gb,
- » II 2D Ex tb IIIC T135°C Db
- » Ex db IIB T4 Gb
- » Ex tb IIIC T135°C Db
- » Ambient temperature from -20°C to +60°C

- » Compliance with Essential Health and Safety Requirements
- » IEC EN 60079-0, IEC EN 60079-31, IEC EN 60079-1

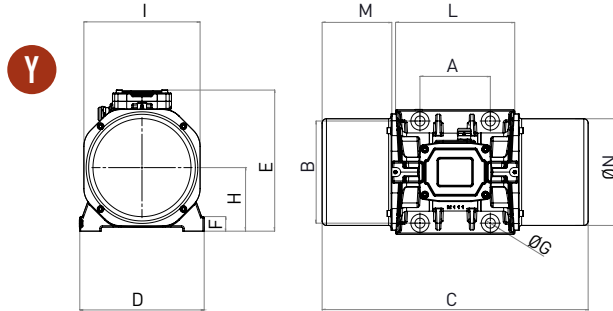
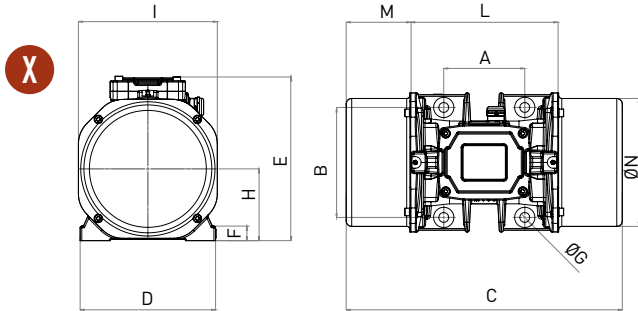

Model		Drawing	Size	DIMENSIONAL SPECIFICATIONS (mm)														
50Hz	60Hz			C		M		A	B	Ø G	Holes n°	D	E	F	H	I	L	N
				50Hz	60Hz	50Hz	60Hz											
MVE 500/1D-50A0	MVE 500/12D-50A0	X	50A0	466	130	120	170	17	4	209	251	27	103	185	205	165		
MVE 800/1D-60A0	MVE 800/12D-60A0	X	60A0	477	111	140	190	17	4	234	283	25	124	240	254	221		
MVE 1100/1D-60A1	MVE 1100/12D-60A1	X	60A1	521	133	140	190	22	4	234	283	25	124	240	254	221		
MVE 1500/1D-60A0	MVE 1500/12D-60A0	X	60A0	597	171	140	190	17	4	234	283	25	124	240	254	221		
MVE 1600/1D-70A0	MVE 1600/12D-70A0	Y	70A0	586	153	155	225	22	4	274	311	32	140	256	279	235		
MVE 2100/1D-70A0	MVE 2100/12D-70A0	Y	70A0	646	183	155	225	22	4	274	311	32	140	256	279	235		
MVE 2600/1D-75A0	MVE 2600/12D-75A0	Y	75A0	724	210	155	255	23.5	4	302	330	30	150	280	304	264		
MVE 3000/1D-75A0	MVE 3000/12D-75A0	Y	75A0	724	210	155	255	23.5	4	302	330	30	150	280	304	264		
MVE 3800/1D-80A0	MVE 3800/12D-80A0	Y	80A0	692	167	180	280	26	4	330	379	33	176	330	358	310		
MVE 4700/1D-80A0	MVE 4700/12D-80A0	Y	80A0	744	193	180	280	26	4	330	379	33	176	330	358	310		

Model		Drawing	Size	DIMENSIONAL SPECIFICATIONS (mm)														
50Hz	60Hz			C		M		A	B	Ø G	Holes n°	D	E	F	H	I	L	N
				50Hz-60Hz	50Hz-60Hz													
MVE 250/075D-50A0	MVE 250/090D-50A0	X	50A0	396	95	120	170	17	4	209	251	27	103	185	205	165		
MVE 400/075D-50A0	MVE 400/090D-50A0	X	50A0	466	130	120	170	17	4	209	251	27	103	185	205	165		
MVE 650/075D-60A0	MVE 650/090D-60A0	X	60A0	477	111	140	190	17	4	234	283	25	124	240	254	221		
MVE 900/075D-60A1	MVE 900/090D-60A1	X	60A1	521	133	140	190	22	4	234	283	25	124	240	254	221		
MVE 1300/075D-70A0	MVE 1300/090D-70A0	Y	70A0	586	153	155	225	22	4	274	311	32	140	256	279	235		
MVE 2100/075D-75A0	MVE 2100/090D-75A0	Y	75A0	724	210	155	255	23.5	4	302	330	30	150	280	304	264		
MVE 3100/075D-80A0	MVE 3100/090D-80A0	Y	80A0	692	167	180	280	26	4	330	379	33	176	330	358	310		
MVE 3800/075D-80A0	MVE 3800/090D-80A0	Y	80A0	744	193	180	280	26	4	330	379	33	176	330	358	310		

Notes:

.....

.....

.....

.....

NOTE: Dimensions with coarse degree of accuracy related to UNI 22768/1

This information is provided without warranty, representation, inducement or licence of any kind. It is accurate to the best OLI knowledge or is obtained from sources believed to be accurate. OLI therefore assumes no legal responsibility. The latest and most updated information are available online.



CLASS I DIV.1  
GROUP C,D T4

- » Class I, Div.1 Group C, D T4 IP66
- » Conform to UL 1004-1, UL 1004-3, UL1203, UL674, CSA C22.2 No.145, CSA C22.2 No.30-M1986.

STANDARD

INCREASED SAFETY

EXPLOSION-PROOF

GRAIN PROCESSING

SCREEN VIBRATOR

STAINLESS STEEL

FLANGED DRIVE



# MVE-Milling GRAIN PROCESSING



Ex II 3D Temp. Class: ● 100 °C ● 135 °C

\* Terminal Connections: Y High Voltage; ▲ Low Voltage

## 6 POLES – 1000/1200 rpm – Destoner / Densimetric Table

Wm (kgcm)		Model		Centrifugal Force (kg)		Weight (kg)		ELECTRICAL SPECIFICATIONS							
								Input Power (kW)		Standard Nominal Current		* Terminal Connection	Ia / In		Cable Gland
50Hz	60Hz	50Hz	60Hz	50Hz	60Hz	50Hz	60Hz	50Hz (400V)	60Hz (460V)	Y	50Hz		60Hz	Metric	
111	88.5	MVE 610/1N-51A0	MVE 610/12N-51A0	622	739	40	35	0.35	0.40		1.22	1.15	Y	3.0	3.0
138	-	MVE 750/1N-58A0	NA	771	-	-	39.5	0.75	-	1.42	-	Y	3.4	-	M25 ●

## 8 POLES – 750 rpm – Grain Purifier

Wm (kgcm)		Model		Centrifugal Force (kg)		Weight (kg)		ELECTRICAL SPECIFICATIONS							
								Input Power (kW)		Standard Nominal Current		* Terminal Connection	Ia / In		Cable Gland
50Hz	60Hz	50Hz	60Hz	50Hz	60Hz	50Hz	60Hz	50Hz (400V)	60Hz (460V)	Y	50Hz		60Hz	Metric	
383	-	MVE 1200/075N-60A	NA	1203	-	94	-	0.65	-		1.30	-	Y	2.5	-
471	-	MVE 1400/075N-60A	NA	1480	-	104	-	0.65	-	1.50	-	Y	2.5	-	M25 ●

## 10 POLES – 600/720 rpm – Grain Purifier

Wm (kgcm)		Model		Centrifugal Force (kg)		Weight (kg)		ELECTRICAL SPECIFICATIONS							
								Input Power (kW)		Standard Nominal Current		* Terminal Connection	Ia / In		Cable Gland
50Hz	60Hz	50Hz	60Hz	50Hz	60Hz	50Hz	60Hz	50Hz (400V)	60Hz (460V)	Y	50Hz		60Hz	Metric	
247	247	MVE 505/060N-51A0	MVE 505/072N-51A0	497	715	54		0.35	0.35		1.22	0.98	Y	2.8	2.8
274	274	MVE 550/060N-51A0	MVE 550/072N-51A0	551	793	57		0.35	0.35	1.22	0.98	Y	2.8	2.8	M20 ●
329	329	MVE 780/060N-61A0	MVE 780/072N-61A0	661	952	73		0.40	0.40	1.20	1.00	Y	2.5	2.5	M20 ●
383	383	MVE 1200/060N-60A	MVE 1200/072N-60A0	770	1110	94		0.78	0.78	1.40	1.30	Y	2.5	2.5	M25 ●
471	471	MVE 1400/060N-60A	MVE 1400/072N-60A0	947	1364	104		0.78	0.78	1.40	1.30	Y	2.5	2.5	M25 ●

## 12 POLES – 600 rpm – Grain Purifier

Wm (kgcm)		Model		Centrifugal Force (kg)		Weight (kg)		ELECTRICAL SPECIFICATIONS							
								Input Power (kW)		Standard Nominal Current		* Terminal Connection	Ia / In		Cable Gland
50Hz	60Hz	50Hz	60Hz	50Hz	60Hz	50Hz	60Hz	50Hz (400V)	60Hz (460V)	Y	50Hz		60Hz	Metric	
-	247	NA	MVE 505/059N-51A0	-	497	54		-	0.35		-	0.98	Y	-	2.8
-	274	NA	MVE 550/059N-51A0	-	551	57		-	0.35	-	0.98	Y	-	2.8	M20 ●
-	329	NA	MVE 780/059N-61A0	-	661	73		-	0.40	-	1	Y	-	2.3	M20 ●

MVE-MILLING



60Hz masses = 50Hz masses adjusted at 100%

To convert kg into Newton:  $N = 9.81 \cdot kg$



- » II3D Ex tc IIIC Tx IP66
- » Equipment and protective system intended for use in potentially explosive atmospheres (Zone 22) - Directive 2014/34/UE
- » Compliance with Essential Health and Safety Requirements
- » EN 60079-0, EN 60079-31

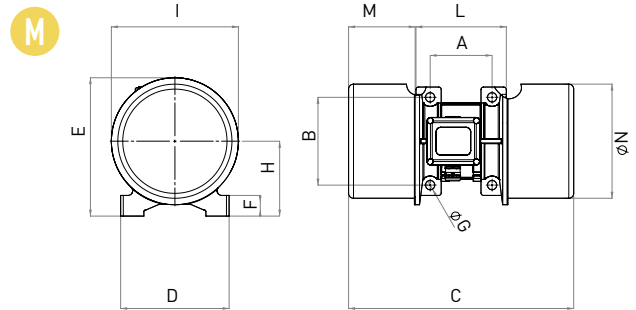
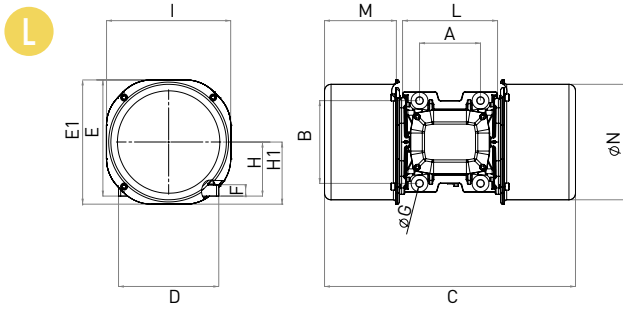

Model		Drawing
50Hz	60Hz	
MVE 610/1N-51A0	MVE 610/12N-51A0	M
MVE 750/1N-58A0	NA	M

DIMENSIONAL SPECIFICATIONS (mm)																
Size	C		M		A	B	Ø G	Holes		D	E	F	H	I	L	N
	50Hz	60Hz	50Hz	60Hz				N°								
51A0	434		117		120	170	17	4		208	223	25	105	203	192	184
58A0	436		129		120	170	17	4		210	268	40	145	246	175	221

Model		Drawing
50Hz	60Hz	
MVE 1200/075N-60A	NA	L
MVE 1400/075N-60A	NA	L

DIMENSIONAL SPECIFICATIONS (mm)																		
Size	C		M		A	B	Ø G	Holes		D	E	E1	F	H	H1	I	L	N
	50Hz	60Hz	50Hz	60Hz				N°										
60A0	576		165		140	190	17	4		230	266	285	26	124	143	285	218	265
60A0	576		165		140	190	17	4		230	266	285	26	124	143	285	218	265

Model		Drawing
50Hz	60Hz	
MVE 505/060N-51A0	MVE 505/072N-51A0	L
MVE 550/060N-51A0	MVE 550/072N-51A0	L
MVE 780/060N-61A0	MVE 780/072N-61A0	L
MVE 1200/060N-60A	MVE 1200/072N-60A0	L
MVE 1400/060N-60A	MVE 1400/072N-60A0	L

DIMENSIONAL SPECIFICATIONS (mm)																		
Size	C		M		A	B	Ø G	Holes		D	E	E1	F	H	H1	I	L	N
	50Hz	60Hz	50Hz	60Hz				N°										
51A0	492		134		120	170	17	4		208	225	240	22	105	120	240	192	222
51A0	492		134		120	170	17	4		208	225	240	22	105	120	240	192	222
61A0	576		165		140	190	17	4		230	266	285	26	124	143	285	218	265
60A0	576		165		140	190	17	4		230	266	285	26	124	143	285	218	265
60A0	576		165		140	190	17	4		230	266	285	26	124	143	285	218	265

Model		Drawing
50Hz	60Hz	
NA	MVE 505/059N-51A0	L
NA	MVE 550/059N-51A0	L
NA	MVE 780/059N-61A0	L

DIMENSIONAL SPECIFICATIONS (mm)																		
Size	C		M		A	B	Ø G	Holes		D	E	E1	F	H	H1	I	L	N
	50Hz	60Hz	50Hz	60Hz				N°										
51A0	492		134		120	170	17	4		208	225	240	22	105	120	240	192	222
51A0	492		134		120	170	17	4		208	225	240	22	105	120	240	192	222
61A0	576		165		140	190	17	4		230	266	285	26	124	143	285	218	265

Notes:

.....

.....

.....

.....

NOTE: Dimensions with coarse degree of accuracy related to UNI 22768/1

This information is provided without warranty, representation, inducement or licence of any kind. It is accurate to the best OLI knowledge or is obtained from sources believed to be accurate. OLI therefore assumes no legal responsibility. The latest and most updated information are available online.



» Declaration of conformity "type B" according to: 2014/35/UE - 2006/42/EC - EN 60034-1  
 » Conform to UL1446 and CSA 22.2 No 0-10

STANDARD

INCREASED SAFETY

EXPLOSION-PROOF

GRAIN PROCESSING

SCREEN VIBRATOR

STAINLESS STEEL

FLANGED DRIVE

# MVE-SV SCREEN VIBRATOR



Ex II 2G: Temp. Class **T4**  
 Class I Div.1: Temp. Class **T4**  
 Ex II 2D Temp. Class: ● **135 °C**

\* Terminal Connections: **Y** High Voltage; **▲** Low Voltage

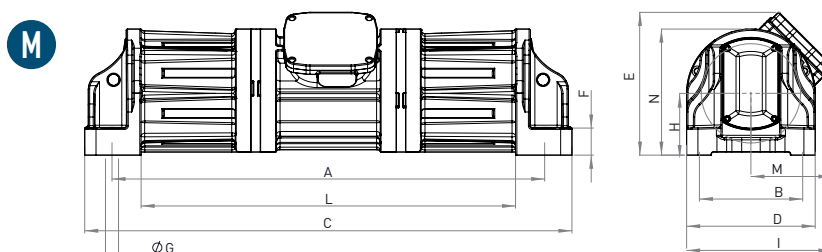

## 4 POLES EXPLOSION PROOF – 1500/1800 rpm

Wm (kgcm)		Model		Centrifugal Force (kg)		Weight (kg)		ELECTRICAL SPECIFICATIONS							
50Hz	60Hz	50Hz	60Hz	50Hz	60Hz	50Hz	60Hz	Input Power (kW)		Standard Nominal Current		* Terminal Connection	Ia / In (Ampere)		Cable Gland
								50Hz	60Hz	50Hz (400V)	60Hz (460V)		50Hz	60Hz	Metric
279	193	MVE 3500/15D-SV-75A0	MVE 3500/18D-SV-75A0	3,500	3,502	180	170	2.2	2.6	4.3	4.3	Y	6.5	6.5	3/4" NPT 110°C ●
279	193	MVE 3500/15D-SV-75D0	MVE 3500/18D-SV-75D0	3,500	3,502	180	170	2.2	2.6	4.3	4.3	Y	6.5	6.5	3/4" NPT 110°C ●
417	292	MVE 5300/15D-SV-80A0	MVE 5300/18D-SV-80A0	5,240	5,283	211	200	2.6	3.0	5.5	5.2	Y	7.1	7.0	3/4" NPT 110°C ●
620	434	MVE 8000/15D-SV-85A0	MVE 8000/18D-SV-85A0	7,790	7,851	280	260	3.2	3.8	6.3	6.3	Y	7.1	7.0	3/4" NPT 110°C ●

**NOTE:** The Model name in the standard range is different: the letter "D" changes in "N".

## 4 POLES STANDARD RANGE – 1500/1800 rpm



The MVE-SV is available also as "standard" range, with Ex II 3D certification: Ex II 3D Temp. Class: ● 135 °C  
 Electrical and dimensional specifications are the same as the "explosion proof" range.



- » II 3D Ex tc IIIC Tx IP66
- » Equipment and protective system intended for use in potentially explosive atmospheres (Zone 22) - Directive 2014/34/UE
- » Compliance with Essential Health and Safety Requirements
- » EN 60079-0, EN 60079-31



- » Declaration of conformity "type B" according to: 2014/35/UE - 2006/42/EC - EN 60034-1
- » Conform to UL1446 and CSA 22.2 No 0-10

SV SIZE 75A0



SV SIZE 85A0



**NOTE:** Adjustable centrifugal force.

To convert kg into Newton: **N = 9.81 · kg**



- » II 2G Ex db IIB T4 Gb,
- » II 2D Ex tb IIIC T135°C Db
- » Ex db IIB T4 Gb
- » Ex tb IIIC T135°C Db
- » Ambient temperature from -20°C to +60°C

- » Compliance with Essential Health and Safety Requirements
- » IEC EN 60079-0, IEC EN 60079-31, IEC EN 60079-1



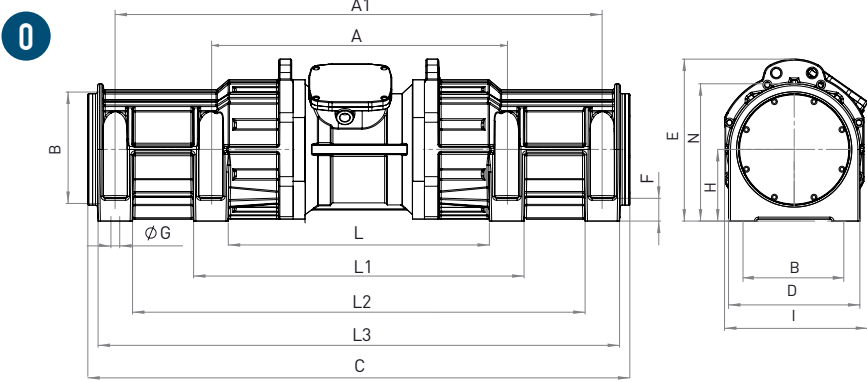
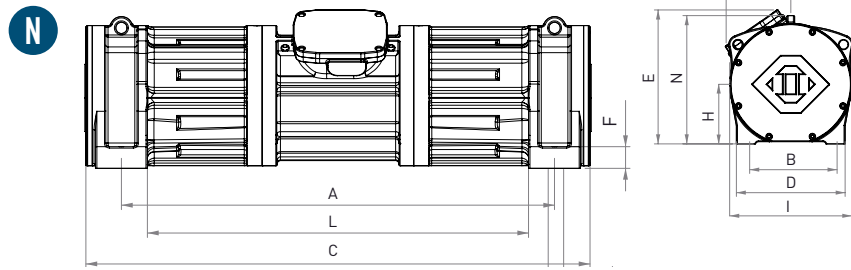

DIMENSIONAL SPECIFICATIONS (mm)

Model		Drawing	Size	DIMENSIONAL SPECIFICATIONS (mm)																
50Hz	60Hz			C	M	A	A1	B	ØG	Holes N°	D	E	F	H	I	L	L1	L2	L3	N
MVE 3500/15D-SV-75A0	MVE 3500/18D-SV-75A0	M	75A0	1,080	179	959	-	229	29	4	285	316	60	137	322	830	-	-	-	279
MVE 3500/15D-SV-75D0	MVE 3500/18D-SV-75D0	M	75D0	1,080	179	959	-	241	20	4	285	316	60	137	322	830	-	-	-	279
MVE 5300/15D-SV-80A0	MVE 5300/18D-SV-80A0	N	80A0	1,116	170	959	-	229	29	4	285	351	48	156	333	844	-	-	-	316
MVE 8000/15D-SV-85A0	MVE 8000/18D-SV-85A0	O	85A0	1,425	/	800	1,280	280	22	8	330	407	57	180	360	714	886	1,193	1,366	345

Notes:

.....

.....

.....

.....

NOTE: Dimensions with coarse degree of accuracy related to UNI 22768/1

This information is provided without warranty, representation, inducement or licence of any kind. It is accurate to the best OLI knowledge or is obtained from sources believed to be accurate. OLI therefore assumes no legal responsibility. The latest and most updated information are available online.

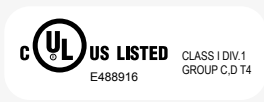

- » Class I, Div.1 Group C, D T4 IP66
- » Conform to UL 1004-1, UL 1004-3, UL1203, UL674, CSA C22.2 No.145, CSA C22.2 No.30-M1986.

Ex II 3D Temp. Class: ● 100 °C ● 135 °C

\* Terminal Connections: Y High Voltage; ▲ Low Voltage

## 2 POLES - 3000/3600 rpm

Wm (kgcm)		Model		Centrifugal Force (kg)		Weight (kg)		ELECTRICAL SPECIFICATIONS								
50Hz	60Hz	50Hz	60Hz	50Hz	60Hz	50Hz	60Hz	Input Power (kW)		Standard Nominal Current		* Terminal Connection	Ia / In		Cable Gland	
50Hz	60Hz	50Hz	60Hz	50Hz	60Hz	50Hz	60Hz	50Hz	60Hz	50Hz (400V)	60Hz (460V)		50Hz	60Hz		Metric
6.4	4.5	MVE 300/3N-SS-30A0	MVE 300/36N-SS-30A0	321	323	16		0.25	0.28	0.52	0.45	Y	3.8	3.7	M20	●
14.9	10.6	MVE 700/3N-SS-40A0	MVE 700/36N-SS-40A0	758	765	25		0.59	0.61	1.25	1.24	Y	4.5	5.2	M20	●
15.7	11.1	MVE 800/3N-SS-50A0	MVE 800/36N-SS-50A0	794	800	32	31	0.70	0.84	1.45	1.50	Y	4.0	4.0	M20	●

## 4 POLES - 1500/1800 rpm

Wm (kgcm)		Model		Centrifugal Force (kg)		Weight (kg)		ELECTRICAL SPECIFICATIONS								
50Hz	60Hz	50Hz	60Hz	50Hz	60Hz	50Hz	60Hz	Input Power (kW)		Standard Nominal Current		* Terminal Connection	Ia / In		Cable Gland	
50Hz	60Hz	50Hz	60Hz	50Hz	60Hz	50Hz	60Hz	50Hz	60Hz	50Hz (400V)	60Hz (460V)		50Hz	60Hz		Metric
15.4	10.8	MVE 200/15N-SS-30A0	MVE 200/18N-SS-30A0	194	196	18.5		0.12	0.15	0.49	0.50	Y	2.2	2.2	M20	●
40.1	28.1	MVE 500/15N-SS-40A0	MVE 500/18N-SS-40A0	504	508	30		0.35	0.40	1.06	1.09	Y	3.0	2.9	M20	●
56.8	39.4	MVE 710/15N-SS-50A0	MVE 710/18N-SS-50A0	714	712	39		0.62	0.73	1.32	1.20	Y	3.2	3.4	M20	●
88.7	62.0	MVE 1100/15N-SS-50A0	MVE 1100/18N-SS-50A0	1,114	1,122	47		0.64	0.77	1.40	1.35	Y	4.0	4.0	M20	●
108.6	76.7	MVE 1400/15N-SS-60A0	MVE 1400/18N-SS-60A0	1,364	1,388	65		0.70	0.84	1.78	1.78	Y	4.2	4.2	M25	●
187.7	137.4	MVE 2400/15N-SS-60A0	MVE 2400/18N-SS-60A0	2,358	2,485	70		1.57	1.88	3.20	3.20	Y	5.1	5.1	M25	●

## 6 POLES - 1000/1200 rpm

Wm (kgcm)		Model		Centrifugal Force (kg)		Weight (kg)		ELECTRICAL SPECIFICATIONS								
50Hz	60Hz	50Hz	60Hz	50Hz	60Hz	50Hz	60Hz	Input Power (kW)		Standard Nominal Current		* Terminal Connection	Ia / In		Cable Gland	
50Hz	60Hz	50Hz	60Hz	50Hz	60Hz	50Hz	60Hz	50Hz	60Hz	50Hz (400V)	60Hz (460V)		50Hz	60Hz		Metric
33.5	23.4	MVE 200/1N-SS-40A0	MVE 200/12N-SS-40A0	187	188	28		0.15	0.18	0.65	0.62	Y	2.2	2.2	M20	●
91.9	91.9	MVE 510/1N-SS-50A0	MVE 510/12N-SS-50A0	513	739	46		0.55	0.40	1.22	1.15	Y	3.0	2.9	M20	●
137.4	108.6	MVE 800/1N-SS-60A0	MVE 800/12N-SS-60A0	767	873	60	58	0.75	0.80	1.42	1.32	Y	3.4	3.3	M25	●
284.8	196.5	MVE 1500/1N-SS-60A0	MVE 1500/12N-SS-60A0	1,590	1,580	84	73	0.90	1.08	1.80	2.00	Y	3.5	3.5	M25	●

## 8 POLES - 750/900 rpm

Wm (kgcm)		Model		Centrifugal Force (kg)		Weight (kg)		ELECTRICAL SPECIFICATIONS								
50Hz	60Hz	50Hz	60Hz	50Hz	60Hz	50Hz	60Hz	Input Power (kW)		Standard Nominal Current		* Terminal Connection	Ia / In		Cable Gland	
50Hz	60Hz	50Hz	60Hz	50Hz	60Hz	50Hz	60Hz	50Hz	60Hz	50Hz (400V)	60Hz (460V)		50Hz	60Hz		Metric
33.4		MVE 150/075N-SS-40A0	MVE 150/090N-SS-40A0	105	151	30		0.23	0.25	1.14	1.14	Y	1.7	1.7	M20	●
84.0		MVE 400/075N-SS-50A0	MVE 400/090N-SS-50A0	264	380	46		0.25	0.30	0.90	0.89	Y	2.1	2.1	M20	●
137.3		MVE 650/075N-SS-60A0	MVE 650/090N-SS-60A0	431	621	63		0.37	0.45	1.20	1.20	Y	2.4	2.4	M25	●
187.7		MVE 900/075N-SS-60A0	MVE 900/090N-SS-60A0	589	849	70		0.55	0.54	1.23	1.29	Y	2.7	2.7	M25	●

SIZE 30A0

SIZE 50A0



2, 4, 6 POLES  
60Hz masses = 50Hz masses adjusted at 70%



8 POLES  
60Hz masses = 50Hz masses adjusted at 100%

To convert kg into Newton:  $N = 9.81 \cdot kg$



» II3D Ex tc IIIC Tx IP66  
» Equipment and protective system intended for use in potentially explosive atmospheres (Zone 22) - Directive 2014/34/UE  
» Compliance with Essential Health and Safety Requirements  
» EN 60079-0, EN 60079-31

P

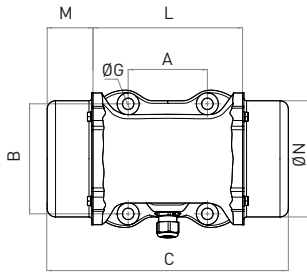
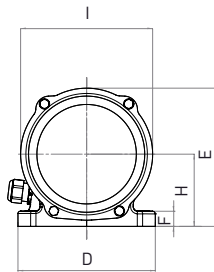

Q

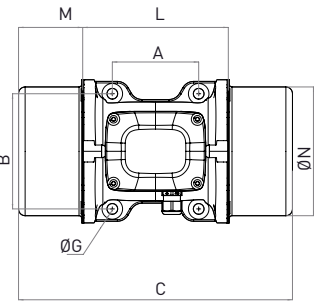
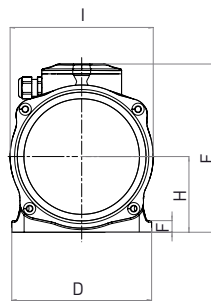

DIMENSIONAL SPECIFICATIONS (mm)

Model		Drawing	Size	C		M		A	B	Ø G	Holes	D	E	F	H	I	L	N	
50Hz	60Hz			N°															
MVE 300/3N-SS-30A0	MVE 300/36N-SS-30A0				P	30A0	50Hz	60Hz	50Hz	60Hz									
MVE 700/3N-SS-40A0	MVE 700/36N-SS-40A0	Q	40A0	333		78		105	140	13	4	170	204	14	92	174	174	156	
MVE 800/3N-SS-50A0	MVE 800/36N-SS-50A0	Q	50A0	324		63.5		120	170	17	4	208	223	18	96	185	197	165	

DIMENSIONAL SPECIFICATIONS (mm)

Model		Drawing	Size	C		M		A	B	Ø G	Holes	D	E	F	H	I	L	N	
50Hz	60Hz			N°															
MVE 200/15N-SS-30A0	MVE 200/18N-SS-30A0				P	30A0	50Hz	60Hz	50Hz	60Hz									
MVE 500/15N-SS-40A0	MVE 500/18N-SS-40A0	Q	40A0	333		78		105	140	13	4	170	204	14	92	174	174	156	
MVE 710/15N-SS-50A0	MVE 710/18N-SS-50A0	Q	50A0	388		95		120	170	17	4	208	223	18	96	185	197	165	
MVE 1100/15N-SS-50A0	MVE 1100/18N-SS-50A0	Q	50A0	458		129		120	170	17	4	208	223	18	96	185	192	170	
MVE 1400/15N-SS-60A0	MVE 1400/18N-SS-60A0	Q	60A0	445		111		140	190	17	4	230	250	26	124	240	218	221	
MVE 2400/15N-SS-60A0	MVE 2400/18N-SS-60A0	Q	60A0	489		133		140	190	17	4	230	250	26	124	240	218	221	

DIMENSIONAL SPECIFICATIONS (mm)

Model		Drawing	Size	C		M		A	B	Ø G	Holes	D	E	F	H	I	L	N	
50Hz	60Hz			N°															
MVE 200/1N-SS-40A0	MVE 200/12N-SS-40A0				Q	40A0	50Hz	60Hz	50Hz	60Hz									
MVE 510/1N-SS-50A0	MVE 510/12N-SS-50A0	Q	50A0	458		129		120	170	17	4	208	223	18	96	185	192	170	
MVE 800/1N-SS-60A0	MVE 800/12N-SS-60A0	Q	60A0	445		111		140	190	17	4	230	250	26	124	240	218	221	
MVE 1500/1N-SS-60A0	MVE 1500/12N-SS-60A0	Q	60A0	565	489	171	133	140	190	17	4	230	250	26	124	240	218	221	

DIMENSIONAL SPECIFICATIONS (mm)

Model		Drawing	Size	C		M		A	B	Ø G	Holes	D	E	F	H	I	L	N	
50Hz	60Hz			N°															
MVE 150/075N-SS-40A0	MVE 150/090N-SS-40A0				Q	40A0	50Hz	60Hz	50Hz	60Hz									
MVE 400/075N-SS-50A0	MVE 400/090N-SS-50A0	Q	50A0	458		129		120	170	17	4	208	223	18	96	185	192	170	
MVE 650/075N-SS-60A0	MVE 650/090N-SS-60A0	Q	60A0	445		111		140	190	17	4	230	250	26	124	240	218	221	
MVE 900/075N-SS-60A0	MVE 900/090N-SS-60A0	Q	60A0	489		133		140	190	17	4	230	250	26	124	240	218	221	

Notes:

.....

.....

.....

NOTE: Dimensions with coarse degree of accuracy related to UNI 22768/1

This information is provided without warranty, representation, inducement or licence of any kind. It is accurate to the best OLI knowledge or is obtained from sources believed to be accurate. OLI therefore assumes no legal responsibility. The latest and most updated information are available online.



» Declaration of conformity "type B" according to: 2014/35/UE - 2006/42/EC - EN 60034-1  
 » Conform to UL1446 and CSA 22.2 No 0-10

STANDARD

INCREASED SAFETY

EXPLOSION-PROOF

GRAIN PROCESSING

SCREEN VIBRATOR

STAINLESS STEEL

FLANGED DRIVE



# MVE-FD FLANGED DRIVE

## Applications

The FD series have been designed to be used on horizontal, inclined, mobile or stationary vibrating screens. In fact, thanks to their design and performance they can be used on many applications.

### LIST OF APPLICATIONS

- Circular / elliptical motion screen
- Circular motion inclined feeders
- Dewatering screen
- Scalping screen
- Vibrating machines and plants for aggregates, soil and minerals processing



Horizontal screen with two MVE-FD

## Advantages

### PLUG & PLAY: EASY AND FAST

The installation of the FD vibrator on the application is very simple and its replacement is very quick.

### MODULARITY

The use of FD requires few structural elements: both design phase and construction are made simpler.

### BUILT TO LAST

The FD series has been designed and built with the aim of reaching a life time of more than 20,000 hours, in any condition.

### VERSATILE

The FD series can be operated via VFD inverters, making it a versatile drive for screens.

### MVE-FD

PROBLEM SOLVING	Avoids the use of eccentric shafts with oil lubrication system.
-----------------	---

### FEATURES

INPUT VOLTAGE	400V (50Hz) or 460V (60Hz)
AMBIENT TEMPERATURE	-20 °C / + 40 °C
ENCLOSURE PROTECTION	IP 66
THERMAL PROTECTION	PTC Thermistor 130 °C
INSULATION CLASS	F

SIZE 80AX A



SIZE 91AX A



SIZE 110BS B



- » II3D Ex tc IIIC Tx IP66
- » Equipment and protective system intended for use in potentially explosive atmospheres [Zone 22] - Directive 2014/34/UE
- » Compliance with Essential Health and Safety Requirements
- » EN 60079-0, EN 60079-31

Product code digit for masses follows the scheme as below:



Ex II 3D Temp. Class: ● 135 °C

\* Terminal Connections: Y High Voltage; Δ Low Voltage

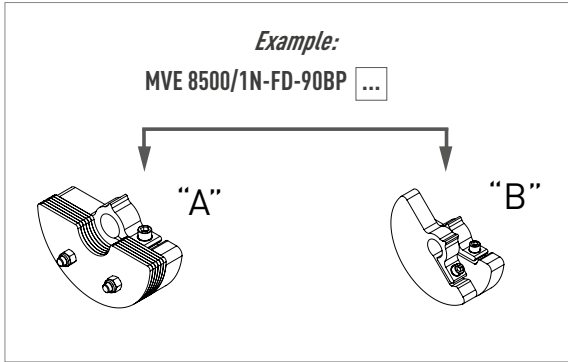

## 6 POLES - 1000/1200 rpm

Wm (kgcm)		Model		Centrifugal Force (kg)		Weight (kg)		ELECTRICAL SPECIFICATIONS							
								Input Power (kW)		Nominal Current		* Terminal Connection	Ia / In (Ampere)		Cable Gland
50Hz	60Hz	50Hz	60Hz	50Hz	60Hz	50Hz	60Hz	50Hz	60Hz	400V 50Hz	460V 60Hz		50Hz	60Hz	Metric
806	654	MVE 4500/1N-FD-80AX A	MVE 5200/12N-FD-80AX A	4,500	5,264	205	200	3.6	3.6	7.5	6.9	Y	4.5	4.3	M25 ●
960	806	MVE 5500/1N-FD-80AX A	MVE 6500/12N-FD-80AX A	5,360	6,480	243	231	5.8	5.8	12	10.5	Y	5.5	5.3	M25 ●
1,518	1,058	MVE 8500/1N-FD-90BP A	MVE 8500/12N-FD-90BP A	8,480	8,511	334	330	6.1	6.4	14.1	12.7	Δ	6.4	6.4	M32 ●
1,870	1,518	MVE 10500/1N-FD-91BP A	MVE 12500/12N-FD-91BP A	10,446	12,211	408	387	6.4	7.7	12.9	14.5	Δ	5.8	6.4	M32 ●
2,218	/	MVE 12500/1N-FD-91BP A	/	12,391	/	437	/	8	/	17.1	/	Δ	6.2	/	M32 ●
2,634	1,856	MVE 15000/1N-FD-105BR B	MVE 15000/12N-FD-105BR B	14,706	14,923	674	632	11.9	14.2	21	21	Δ	5.8	5.8	M32 ●
3,220	2,147	MVE 17500/1N-FD-105BR B	MVE 17500/12N-FD-105BR B	17,980	17,264	700	640	11.9	14.2	21	21	Δ	5.6	5.9	M32 ●
3,632	2,525	MVE 19500/1N-FD-105BR B	MVE 19500/12N-FD-105BR B	20,285	20,299	720	680	12	14.5	24	24	Δ	5.4	5.6	M32 ●
4,572	3,163	MVE 25000/1N-FD-110BS B	MVE 25000/12N-FD-110BS B	25,532	25,432	982	925	13.9	17	28	28	Δ	4.8	5.3	M32 ●

## 8 POLES - 750/900 rpm

Wm (kgcm)		Model		Centrifugal Force (kg)		Weight (kg)		ELECTRICAL SPECIFICATIONS							
								Input Power (kW)		Nominal Current		* Terminal Connection	Ia / In (Ampere)		Cable Gland
50Hz	60Hz	50Hz	60Hz	50Hz	60Hz	50Hz	60Hz	50Hz	60Hz	400V 50Hz	460V 60Hz		50Hz	60Hz	Metric
806	806	MVE 2600/075N-FD-80AX A	MVE 3700/090N-FD-80AX A	2,531	3,645	207	207	2.5	3	6	6	Y	3.5	3.5	M25 ●
960	960	MVE 3000/075N-FD-80AX A	MVE 4400/090N-FD-80AX A	3,015	4,342	232	232	5	5.9	13.5	14.2	Y	3.6	3.6	M25 ●
1,932	1,932	MVE 6000/075N-FD-90BP A	MVE 8700/090N-FD-90BP A	6,071	8,742	397	397	6.8	7.5	13.4	12.5	Δ	3.5	3.5	M32 ●
2,218	2,218	MVE 7000/075N-FD-91BP A	MVE 10000/090N-FD-91BP A	6,969	10,036	421	421	7	7.7	14.7	13.4	Δ	4.6	3.5	M32 ●
3,713	3,220	MVE 14000/075N-FD-105BR B	MVE 14000/090N-FD-105BR B	11,661	14,563	730	704	9	10.6	19	19	Δ	4.5	5	M32 ●
4,401	3,920	MVE 17000/075N-FD-105BR B	MVE 17000/090N-FD-105BR B	13,822	17,729	753	733	9.1	11	20	20	Δ	5.3	5.8	M32 ●
5,857	4,999	MVE 22000/075N-FD-110BS B	MVE 22000/090N-FD-110BS B	18,395	22,610	970	925	13.8	16.5	28	28	Δ	5.6	5.2	M32 ●

### Notes:

.....

.....

.....

NOTE: Dimensions with coarse degree of accuracy related to UNI 22768/1

This information is provided without warranty, representation, inducement or licence of any kind. It is accurate to the best OLI knowledge or is obtained from sources believed to be accurate. OLI therefore assumes no legal responsibility. The latest and most updated information are available online.



» Declaration of conformity "type B" according to: 2014/35/UE - 2006/42/EC - EN 60034-1  
» Conform to UL1446 and CSA 22.2 No 0-10

STANDARD

INCREASED SAFETY

EXPLOSION-PROOF

MILLING

SCREEN VIBRATOR

STAINLESS STEEL

FLANGED DRIVE



# MVE-FD FLANGED DRIVE

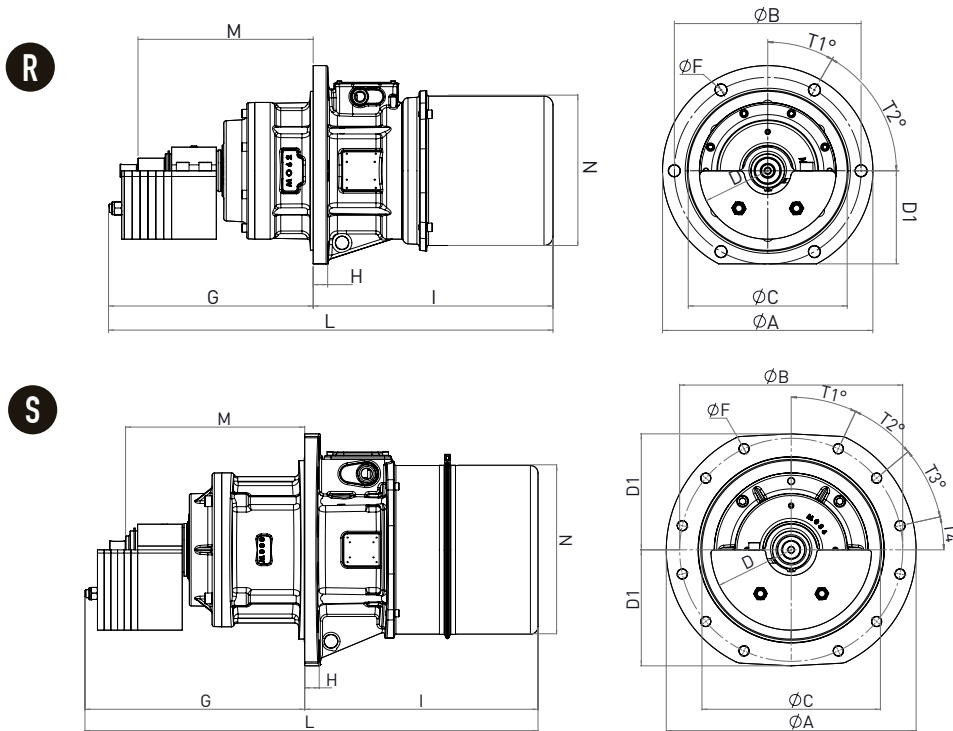

## 6 POLES – 1000/1200 rpm

Model		Drawing	Size	DIMENSIONAL SPECIFICATIONS (mm)												
50Hz	60Hz			Holes	B	F	A	C	D	D1	G		H	I	L	
										50Hz	60Hz			50Hz	60Hz	
MVE 4500/1N-FD-80AX A	MVE 5200/12N-FD-80AX A	R	80AX	6	355	22	400	302	130	177	399	389	28	501	900	890
MVE 5500/1N-FD-80AX A	MVE 6500/12N-FD-80AX A	R	80AX	6	355	22	400	302	130	177	459	429	28	521	980	950
MVE 8500/1N-FD-90BP A	MVE 8500/12N-FD-90BP A	S	90BP	12	500	22	560	400	180	260	411	376	30	460	871	836
MVE 10500/1N-FD-91BP A	MVE 12500/12N-FD-91BP A	S	91BP	12	500	22	560	400	180	260	473.5	458.5	30	523	996	981.5
MVE 12500/1N-FD-91BP A	/	S	91BP	12	500	22	560	400	180	260	488.5	/	30	523	1,011	/
MVE 15000/1N-FD-105BR B	MVE 15000/12N-FD-105BR B	T	105BR	12	590	26	645	480	231	270	675	675	35	520	1,195	1,195
MVE 17500/1N-FD-105BR B	MVE 17500/12N-FD-105BR B	T	105BR	12	590	26	645	480	231	270	675	675	35	520	1,195	1,195
MVE 19500/1N-FD-105BR B	MVE 19500/12N-FD-105BR B	T	105BR	12	590	26	645	480	231	270	675	675	35	520	1,225	1,225
MVE 25000/1N-FD-110BS B	MVE 25000/12N-FD-110BS B	U	110BS	16	640	26	700	520	250	330	675	675	45	559	1,234	1,234

## 8 POLES – 750/900 rpm

Model		Drawing	Size	DIMENSIONAL SPECIFICATIONS (mm)												
50Hz	60Hz			Holes	B	F	A	C	D	D1	G		H	I	L	
										50Hz	60Hz			50Hz	60Hz	
MVE 2600/075N-FD-80AX A	MVE 3700/090N-FD-80AX A	R	80AX	6	355	22	400	302	130	177	399	399	28	501	900	900
MVE 3000/075N-FD-80AX A	MVE 4400/090N-FD-80AX A	R	80AX	6	355	22	400	302	130	177	459	459	28	521	980	980
MVE 6000/075N-FD-90BP A	MVE 8700/090N-FD-90BP A	S	90BP	12	500	22	560	400	180	260	441	441	30	460	901	901
MVE 7000/075N-FD-91BP A	MVE 10000/090N-FD-91BP A	S	91BP	12	500	22	560	400	180	260	488.5	488.5	30	523	1,011	1,011
MVE 14000/075N-FD-105BR B	MVE 14000/090N-FD-105BR B	T	105BR	12	590	26	645	480	231	270	675	675	35	520	1,195	1,195
MVE 17000/075N-FD-105BR B	MVE 17000/090N-FD-105BR B	T	105BR	12	590	26	645	480	231	270	675	675	35	520	1,225	1,225
MVE 22000/075N-FD-110BS B	MVE 22000/090N-FD-110BS B	U	110BS	16	640	26	700	520	250	330	675	675	45	559	1,234	1,234



60Hz masses = 50Hz masses adjusted at 100%

To convert kg into Newton:  $N = 9.81 \cdot kg$



- » II3D Ex tc IIIC Tx IP66
- » Equipment and protective system intended for use in potentially explosive atmospheres [Zone 22] - Directive 2014/34/UE
- » Compliance with Essential Health and Safety Requirements
- » EN 60079-0, EN 60079-31

T

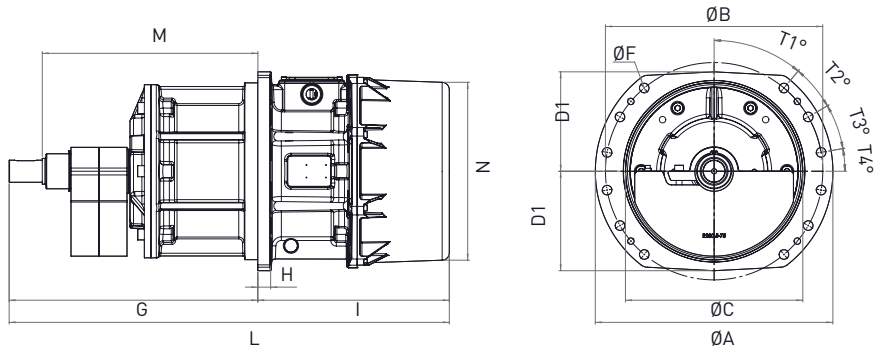

SHAFT EDGE

Type	Q	O	Ø P
Tolerances	± 0.2	H8	g6

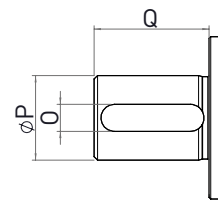

U

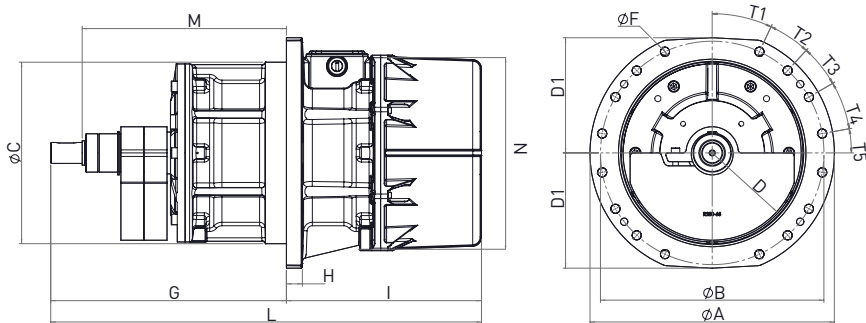

DIMENSIONAL SPECIFICATIONS (mm)

Model		M	N	O	P	Q	T1	T2	T3	T4	T5	Screw
50Hz	60Hz											
MVE 4500/1N-FD-80AX A	MVE 5200/12N-FD-80AX A	333	284	8	25	34	30	60	/	/	/	M20
MVE 5500/1N-FD-80AX A	MVE 6500/12N-FD-80AX A	333	284	8	25	34	30	60	/	/	/	M20
MVE 8500/1N-FD-90BP A	MVE 8500/12N-FD-90BP A	337	378	12	40	36	25	25	27.5	12.5	/	M20
MVE 10500/1N-FD-91BP A	MVE 12500/12N-FD-91BP A	392	378	12	40	36	25	25	27.5	12.5	/	M20
MVE 12500/1N-FD-91BP A	/	392	378	12	40	36	25	25	27.5	12.5	/	M20
MVE 15000/1N-FD-105BR B	MVE 15000/12N-FD-105BR B	585	495	18	60	90	40	20	20	10	/	M24
MVE 17500/1N-FD-105BR B	MVE 17500/12N-FD-105BR B	585	495	18	60	90	40	20	20	10	/	M24
MVE 19500/1N-FD-105BR B	MVE 19500/12N-FD-105BR B	585	495	18	60	90	40	20	20	10	/	M24
MVE 25000/1N-FD-110BS B	MVE 25000/12N-FD-110BS B	575	550	18	60	90	25	17.5	17.5	20	10	M24

DIMENSIONAL SPECIFICATIONS (mm)

Model		M	N	O	P	Q	T1	T2	T3	T4	T5	Screw
50Hz	60Hz											
MVE 2600/075N-FD-80AX A	MVE 3700/090N-FD-80AX A	333	284	8	25	34	30	60	/	/	/	M20
MVE 3000/075N-FD-80AX A	MVE 4400/090N-FD-80AX A	333	284	8	25	34	30	60	/	/	/	M20
MVE 6000/075N-FD-90BP A	MVE 8700/090N-FD-90BP A	337	378	12	40	36	25	25	27.5	12.5	/	M20
MVE 7000/075N-FD-91BP A	MVE 10000/090N-FD-91BP A	392	378	12	40	36	25	25	27.5	12.5	/	M20
MVE 14000/075N-FD-105BR B	MVE 14000/090N-FD-105BR B	585	495	18	60	90	40	20	20	10	/	M24
MVE 17000/075N-FD-105BR B	MVE 17000/090N-FD-105BR B	585	495	18	60	90	40	20	20	10	/	M24
MVE 22000/075N-FD-110BS B	MVE 22000/090N-FD-110BS B	575	550	18	60	90	25	17.5	17.5	20	10	M24

NOTE: Dimensions with coarse degree of accuracy related to UNI 22768/1

This information is provided without warranty, representation, inducement or licence of any kind. It is accurate to the best OLI knowledge or is obtained from sources believed to be accurate. OLI therefore assumes no legal responsibility. The latest and most updated information are available online.



» Declaration of conformity "type B" according to: 2014/35/UE - 2006/42/EC - EN 60034-1  
 » Conform to UL1446 and CSA 22.2 No 0-10

STANDARD

INCREASED SAFETY

EXPLOSION-PROOF

MILLING

SCREEN VIBRATOR

STAINLESS STEEL

FLANGED DRIVE



# INSTALLATION

## Mounting

The base plate surface where the vibrator is mounted has an allowable tolerance of 0.25mm (0.01in), so that the surfaces rest uniformly against each other to avoid internal tension that may cause breakage of the foot of the vibrator.

Use 8.8 type bolts, 8.0 type nuts and flat washers belonging to category A EN ISO 7089 / 7092.

The graph below shows the correct torque settings for the different bolt sizes used on the vibrators.

### Vibrator / Machine interface

Screw		Washer		Clamping torque	
Metric	Imperial	Metric UNI 6592	Imperial Flat washer	(Nm)	(ftlb)
M6	1/4"	6.4 x 12	1/4"	9	6.5
M8	5/16"	8.4 x 16	5/16"	23	16.5
M10	3/8"	10.5 x 20	3/8"	45	33
M12	1/2"	13 x 24	1/2"	80	58
M16	5/8"	17 x 30	5/8"	185	137
M20	13/16"	21 x 37	13/16"	373	275
M22	7/8"	23 x 39	7/8"	550	411
M24	15/16"	25 x 44	15/16"	696	513
M27	1"	28 x 50	1"	873	645
M36	1-3/8"	37 x 66	1-3/8"	1,864	1,370
M42	1 5/8"	37 x 66	1 5/8"	2,850	2,102

### FIXING

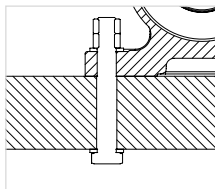

Smooth through borehole  
+ screw  
+ flat washer  
+ nut and conternut

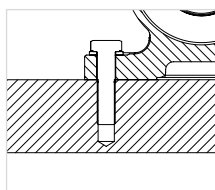

Tapped threaded borehole  
+ screw  
+ flat washer

### SURFACE FLATNESS TOLERANCE

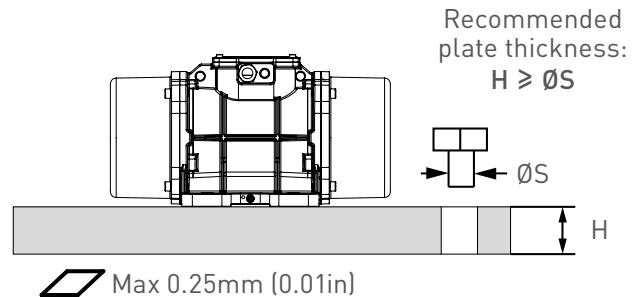

**MACHINED & NOT PAINTED  
SUPPORT PLATE**





## Electrical connection

Verify that the voltage and frequency supply match the ones indicated on the rating plate of the electric vibrator.

If the vibrator is operated via a variable frequency drive do not run it under 20 Hz and not over the rated frequency.

Insert the power cable through the cable gland. The lead-in wires have to be of the eyelet-type, pre-insulated, with a bore that suits the terminals of the junction box in order to prevent overheating of the wire. Use only conductors that have a suitable cross-section.

Connect the lead wires to the pins (as shown in the diagram below) and tighten them with the specified torque.

**Do not forget to fix the earthing cable to the provided studs → Compulsory connection!**

Before closing the junction box make sure that the cover gasket is properly fitted in order to keep the specified IP protection.

For more details on vibrator installation refer to product manuals.

Junction box nuts tightening torque		
Screw	Nm	ftlb
M4	2.5	1.84
M5	4	2.95
M6	5	3.69
M8	6	4.43
M10	8	5.90

### TERMINAL CONNECTIONS

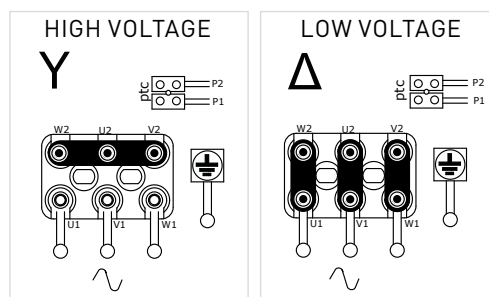

Check "Terminal Connection" column label to know the factory preset connection of each vibrator.

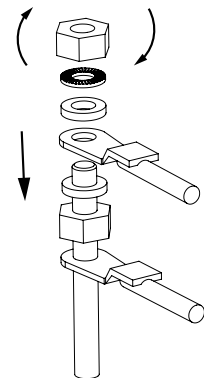

## Overload protection

All electric vibrators **MUST** be connected to a suitable external overload protection.

When using two electric vibrators in sync, each of them has to be connected to an external overload protection that must be interlocked to make sure both vibrators are stopped if one fails.

Always use a thermal-magnetic type vibrator

protection, with delayed cut-off, to avoid stopping the vibrator during start-up when the current draw is higher than the rated running current for a few seconds.

Cut-off of the overload protection should be set at a maximum of +10% of the rated current.



# HOW TO CHANGE THE VIBRATION INTENSITY

## Adjustable masses – Type 1

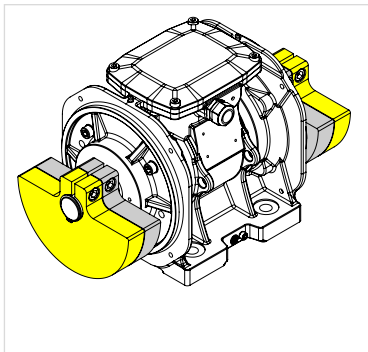

MASSES AT 100%

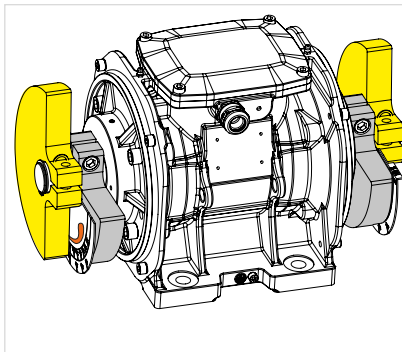

ADJUSTED MASSES

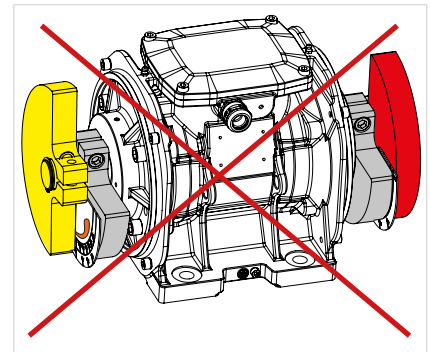

INCORRECTLY ADJUSTED MASSES

### 2 TIPS TO CORRECTLY ADJUST MASSES:

Rotate the mass following the design on the plate: from the thicker tip towards the thin tip.

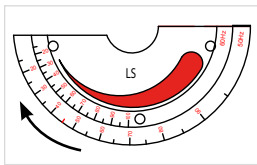

left side of the vibrator.  
for sizes up to 60

Rotate the masses in the opposite direction to the cable gland.

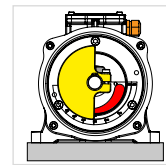

left side

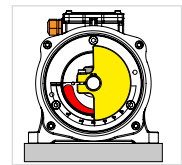

right side

## Adjustable masses – Type 2

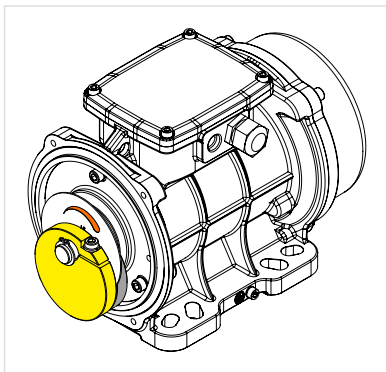

MASSES AT 100%

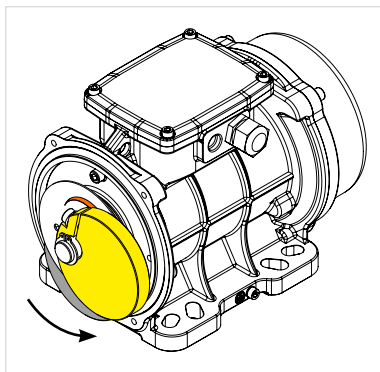

ADJUSTED MASSES

The fissure in the mass indicates the degree of adjustment.

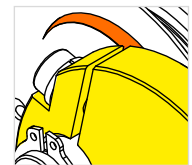

Rotate the mass following the design on the plate: from the thicker tip towards the thin tip.

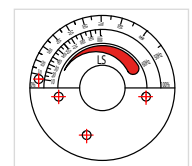

## Adjustable masses – Type 3 (blade masses)

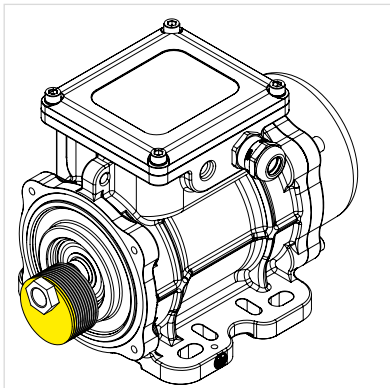

MASSSES AT 100%

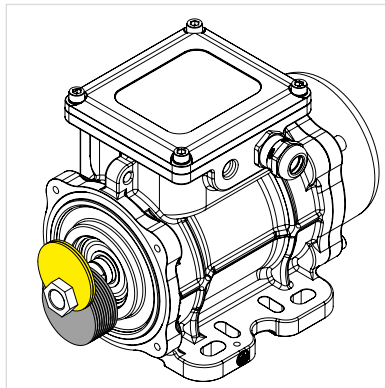

ADJUSTED MASSES

For technical information on the regulation of blade masses refer to the Use and Maintenance Manual.



**Warning:**  
**DO NOT** grease new motors before installation.

OLI motors with roller bearings leave the factory filled with the right quantity of grease while those with ball bearing do not need any lubrication.

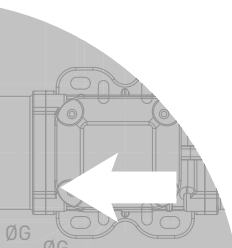

**TECHNICAL DRAWINGS**



---

# WHEN YOU NEED IT, WHERE YOU NEED IT.

## THE WORLDWIDE LEADER IN VIBRATION TECHNOLOGY

[www.olivibra.com](http://www.olivibra.com)

---



### OLI Headquarters

Via Sparato, 14  
41036 Medolla (MO) - Italy

 +39 0535 41 06 11

 [info@olivibra.com](mailto:info@olivibra.com)

### OLI worldwide

OLI Australia	OLI Indonesia	OLI Middle East	OLI Thailand
OLI Brazil	OLI Italy	OLI Nordic	OLI Turkey
OLI China	OLI Korea	OLI Poland	OLI UK
OLI France	OLI Malaysia	OLI Russia	OLI USA
OLI Germany	OLI Malta	OLI South Africa	OLI Vietnam
OLI India	OLI Mexico	OLI Spain	

